

# IBM OEM STORAGE PRODUCTS

## Deskstar DALA-3540

IBM introduced a disk drive for the desktop personal computer marketplace. Available at the 540MB capacity point with AT interface, the drive provided excellent performance and improved reliability.

### *Applications*

- Desktop personal computers

### Features

- \* 528, or 541MB formatted capacity (512 byte/sector), chosen by jumper.
- \* PIO data transfer - mode 3
- \* 48.7 Mb/s (OD) media data rate.
- \* 32.2 Mb/s (ID) media data rate.
- \* Average seek time 12ms (Read).
- \* 4500 RPM.
- \* 96 KB three segment sector buffer.
- \* Read ahead caching with LFU (Least frequently used) segment update.
- \* Industry standard mounting.
- \* The drive can be mounted with any of its six surfaces facing down.
- \* Advanced ECC on the fly.
- \* CHS and LBA addressing modes.
- \* Power saving modes.
- \* Robust design for EMC/RFI.
- \* MR (Magneto Resistive) heads
- \* No-ID(TM) sector format.
- \* MTBF 350,000 hours.

### Benefits

- \* Generic popular storage capacity
- \* Fast interface data rate. (max 11.1Mb/s).
- \* Excellent performance on long records
- \* Fast access to data.
- \* Fast data retrieval in multi-tasking applications
- \* Ease of installation.
- \* Improved data throughput.
- \* Flexibility to support most appropriate addressing.
- \* Reduced power consumption.
  - \* Ideal for energy-efficient systems.
- \* Easy integration across multiple platforms.
- \* High area density, low component count.
- \* More data stored per track, increased sustained data transfer rate.
- \* Assured reliability.

### *Connectors*

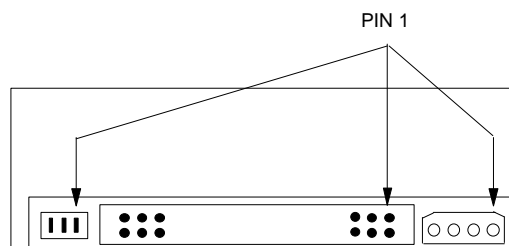

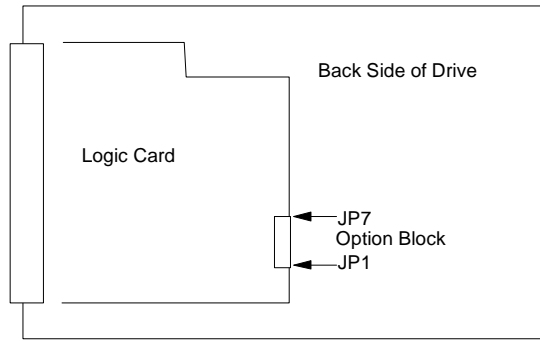

There is a choice of 2 power connections to this drive. One DC power connector is designed to mate with AMP part 1-480424-0 (using AMP pins P/N 350078-4). The other (3 pin) DC power connector is designed to mate with MOLEX 5480-03 (using MOLEX pins 5479). Equivalent connectors may be used. Pin assignments are shown below, as viewed from the end of the drive.



### ***AT Signal Connector***

The drive uses single-ended drivers and receivers. The connector is designed to mate with 3M part 3417-7000 or equivalent.

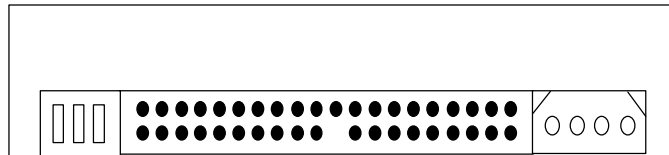

### ***Note:***

It is intended that the hard disk drive should only be in electrical contact with the chassis of the PC at a designated set of mounting holes. Other electrical contact may degrade error rate performance. As a result of this, it is recommended that there should be no metal contact to the hard disk drive except at the mounting holes or the side rails into which the mounting holes are tapped.

## ***Option Block***

### *Jumper Settings*

Jumpers may be fitted to select the following options:

	Pin Numbers
MASTER active	1-2
SLAVE active	3-4
Cable sel	5-6
Write cache	9-10 (Disabled with jumper)
Auto re-allocation	11-12 (Disabled with jumper)

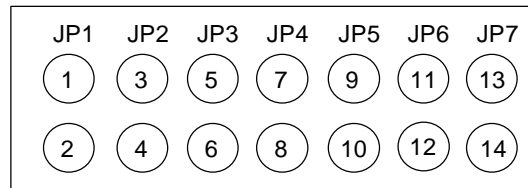

541/528 MB selection 13-14 (541MB with jumper)

### *Auto Reallocation Jumper*

Auto reallocation jumper is checked during the initial power on reset (POR) check. Write cache is disabled when a jumper is fitted. (+) Auto reallocation jumper position needs to be OPEN when a user system wants to use write cache.

#### *Note:*

Auto reallocation only operates, and is mandatory, during write cache operations. Disabling either function by jumper disables both.

### *Write Cache Jumper*

Write cache jumper is checked during the initial POR check.

Write cache is disabled when a jumper is fitted.

### *Shipping Default Settings*

MASTER is set to on (ie jumper on pins 1-2), 541MB capacity set. No other jumpers are fitted.

#### *Note:*

The jumper positions JP1, JP2, JP3 must not be selected concurrently.

## ***Operating Environment***

### *Operating Conditions*

Temperature	5 to 55 degrees C*
Relative Humidity	8 to 90% non-condensing

Maximum Wet Bulb	29.4 degrees C non-condensing
Maximum Temperature Gradient	15 degrees C/Hour
Altitude	-300 to 3000m

*Non-Operating Conditions*

Temperature	-40 to 65 degrees C (shipping) 0 to 65 degrees C (storage)
Relative Humidity	5 to 95% non-condensing
Maximum Wet Bulb Temperature	35 degrees C non-condensing
Altitude	-300 to 12,000m

*Note \*:*

The system is responsible to provide sufficient air movement to maintain surface temperature below 60 degrees C at the center of top cover of the drive.

*Operating shock*

The hard disk drive meets the following criteria while operating in respective conditions described below. The shock test consists of ten shocks inputs in each axis and direction for total of 60. There must be a delay between shock pulses, long enough to allow the drive to complete all necessary error recovery procedure.

*No errors*

5 G, 11ms half-sine shock pulse.

*No data loss, seek errors or permanent damage*

10 G, 11ms half-sine shock pulse.

*No data loss or permanent damage*

15 G, 5ms half-sine shock pulse. 30 G, 4ms half-sine shock pulse.

*Operating Vibration*

Due to the complexity of this subject, we recommend that users contact the IBM technical support group representative to discuss how to perform the necessary measurements if they believe this to be an area which requires evaluation.

***Data Organization***

Logical Layout	DALA	DALA
	-3540	-3540
Jumper 7	attached	not attached
Number of Heads	16	16
Number of Sectors/Track	63	63
Number of Cylinders	1049	1024

Sector Size	512	512
Total Customer Usable Data Sectors	1,057,392	1,032,192
Total Customer Usable Data Bytes	541MB	528MB

***DC Power Requirements***

The following voltage specifications apply at the drive power connector. Damage to the drive electronics may result if the power supply cable is connected or disconnected while power is being applied to the drive (No hot plug/unplug is allowed). There are inductive loads in the drive which could cause destructively high voltage spikes on the drive if the power connection is opened. There is no special power on/off sequencing required.

Nominal Supply Voltages	+5 Volts	+12 Volts
Maximum Ripple (0-10 MHz)	100mV p-p	150mV p-p
Voltage Supply Tolerance (incl. ripple)	+/-5%	+10%/-8%
Power Supply Current (Amps)	+5 Volts	+12 Volts
Start peak	0.50	0.52
Idle average	0.18	0.14
R/W average	0.49	0.17

During the drive start up and seeking, 12 volt ripple is generated by the drive (referred to as dynamic load-ing). If several drives have their power daisy chained together, then the power supply ripple plus other drive's dynamic loading must remain within the regulation tolerance of +10/-8%. A common supply with separate power leads to each drive is a more desirable method of power distribution.

To prevent external electrical noise from interfering with the drive's performance, the drive must be held by four screws in a user system frame which has no electrical level deference at the four screws position, and has less than +/-300 millivolts peak to peak level deference to the drive power connector ground.

***Signal Definition***

The pin assignments of interface signals are listed as follows:

PIN	Signal	I/O	PIN	Signal	I/O
01	-HRESET	I	02	GND	
03	HD07	I/O	04	HD08	I/O
05	HD06	I/O	06	HD09	I/O
07	HD05	I/O	08	HD10	I/O
09	HD04	I/O	10	HD11	I/O
11	HD03	I/O	12	HD12	I/O
13	HD02	I/O	14	HD13	I/O
15	HD01	I/O	16	HD14	I/O
17	HD00	I/O	18	HD15	I/O
19	GND		(20)	Key	

21	DMARQ	O	22	GND
23	-HIOW	I	24	GND
25	-HIOR	I	26	GND
27	HIORDY	O	28	CSEL
29	-DMACK	I	30	GND
31	HIRQ	O	32	-HIOCS16 O
33	HA01	I	34	-PDIAG I/O
35	HA00	I	36	HA02 I
37	-HCSO	I	38	-HCS1 I
39	-DASP	I/O	40	GND

*Note:*

"O" designates an output from the Drive.

"I" designates an input to the Drive.

"I/O" designates an input/output common.

***Cabling***

The maximum cable length from the Host system to the drive, plus the circuit pattern length inside the Host systems, must not exceed 18 inches (45.7 cm).

***Interface***

This data sheet describes some aspects of the host interface to ATA-2 drives. The interface conforms to the working draft of Information Technology-AT Attachment Interface with Extensions (ATA-2) with certain limitations described below.

*Automatic Power Down Sequence*

A hard reset will disable the automatic power down sequence.

*Format Track*

A drive will not perform a physical format. Instead, it will simply write a data pattern of all zeros to the sectors which have been specified by the Format Track command.

*Format Track Interleave Factor*

The drive only supports an interleave factor of 1:1, and may ignore any other specified interleave, without returning an error.

*Write long*

Write long command should be executed for the same sector after Read long command execution. Otherwise, unexpected ECC correctable error may occur, because of the limitation of the emulation technique to support 4 byte ECC mode which is implemented in the drive.

*Seek Overlap*

The drive will wait for the seek to complete before interrupting the host. Therefore, no seek overlap can occur. This will be transparent to the host except that performance may be degraded in certain environments where the host could perform other work while waiting for seek complete, such as multi-tasking operating systems.

#### *Sleep mode*

During Sleep mode the drive will be activated by any command, including, but not limited to, a soft reset.

#### *Drive/Head Register*

Bits 5 and 7 of Drive/Head Register are not written to 0. (These 2 bits are always read as '1' even after host writes to '0'...).

#### *Sleep/Standby/Idle Mode*

When entering sleep, standby or idle mode as a result of a command, the busy bit in the status register will remain set until the transition to the new state is complete.

The following Commands are supported by the Drive:

Commands	(HEX)
Check Power Mode	(E5)
Execute Drive Diagnostics	(90)
Format Track	(50)
Identify Drive	(EC)
Idle	(E3)
Idle Immediate	(E1)
Initialize Drive Parameters	(91)
Read Buffer	(E4)
Read DMA (retry)	(C8)
Read DMA (no retry)	(C9)
Read Long (retry)	(22)
Read Long (no retry)	(23)
Read Multiple	(C4)
Read Sectors (retry)	(20)
Read Sectors (no retry)	(21)
Read Verify Sectors (retry)	(40)
Read Verify Sectors (no retry)	(41)
Recalibrate	(1X)
Seek	(7X)
Set Features	(EF)
Set Multiple	(C6)
Sleep	(E6)
Standby	(E2)
Standby Immediate	(EO)
Write Buffer	(E8)
Write DMA (retry)	(CA)
Write DMA (no retry)	(CB)

Write Long (retry)	(32)
Write Long (no retry)	(33)
Write Multiple	(C5)
Write Sectors (retry)	(30)
Write Sectors (no retry)	(31)
Write Verify	(3C)

### ***Registers***

Address	Input Register	Output Register
1F0h	Data	Data
1F1h	Error	Features
1F2h	Sector Count	Sector Count
1F3h	Sector Number	Sector Number
	*LBA bits 0-7	*LBA bits 0-7
1F4h	Cylinder Low	Cylinder Low
	*LBA bits 8-15	*LBA bits 8-15
1F5h	Cylinder High	Cylinder High
	*LBA bits 16-23	*LBA bits 16-23
1F6h	Drive/Head	Drive/Head
	*LBA bits 24-27	*LBA bits 24-27
1F7h	Status	Command
3F6h	Alternate Status	Device Control
3F7h	Drive Address	Not Used

The host uses the register interface to communicate to and from the drive. The registers are accessed through the host port addresses shown.

The host should not read or write any registers when the Status Register BSY bit = 1.

### ***Note:***

\* Meaning of Register contents when LBA addressing mode used.

### ***Electromagnetic Compatibility***

The Drive meets the following EMC requirements when installed in the user system and exercised with a random accessing routine at maximum data rate:

United States Federal Communication Commission (FCC) Rules and Regulations Part 15, Subject J - Computer Devices "Class B Limits".

European Economic Community (EEC) directive #76/889 related to the control of radio frequency interference and the Verband Deutscher Elektrotechniker (VDE) requirements of Germany (GOP).

### ***Mechanical Data***

#### ***Dimensions***

Height	25.4+/-0.4mm
Width	101.6+/-0.4mm

Depth 146.0+/-0.6mm  
Weight 450g maximum

*Mounting Orientation*

The Drive can be mounted in any axis (6 directions).

The maximum allowable penetration of the mounting screws is (\*1) 3.5mm (\*2) 6mm.

The recommended mounting screw torque is 6 to 10 (KgF.cm)

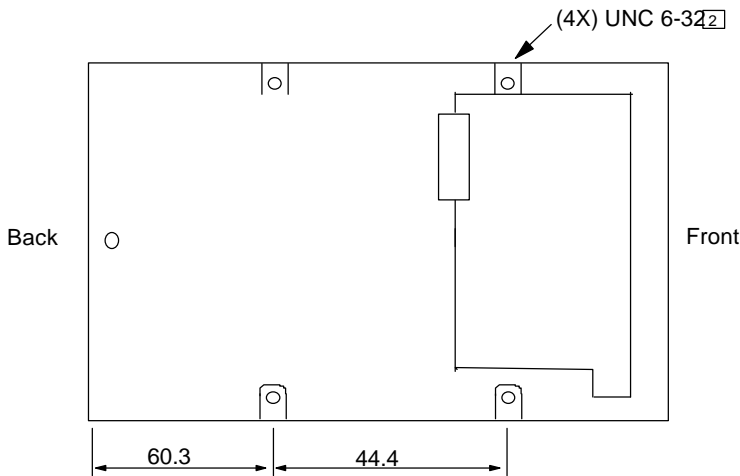
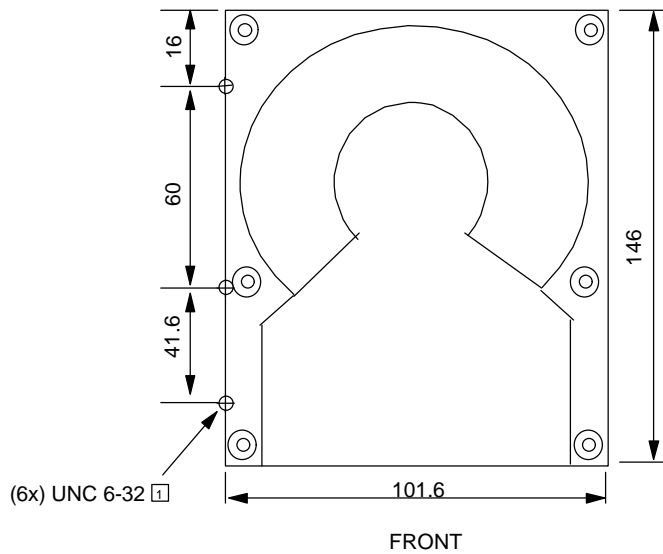

**WARNING:** This disk drive can be damaged by Electro-Static Discharge; please follow recommended ESD procedures before unpacking or handling the drive. Ask your Dealer for details if you need assistance.

**PACKAGING:** The drive must be protected against Electro-Static Discharge especially when being handled. The safest way to avoid damage is to put the drive in an anti-static bag before ESD wrist straps etc, are removed.

Drives should only be shipped in approved containers; severe damage can be caused to the drive if the packaging does not adequately protect against the shock levels induced when a box is dropped. Consult your IBM marketing representative if you do not have an approved shipping container.

AMP is a trademark of AMP Incorporated.

Molex is a trademark of Molex Incorporated.

DATA MATE is a trademark of AMP Incorporated.

This data sheet is not a substitute for the full product specification, which should be used when detailed information is required.

Product Description data represents IBM's design objectives and is provided for comparative purposes; actual results may vary based on a variety of factors. This product data does not constitute a warranty. Questions regarding IBM's warranty terms or methodology used to derive this data should be referred to your IBM OEM representative. Data subject to change without notice.