

HITACHI

Inspire the Next

Product Summary

Hitachi Deskstar 7K400

Ultra ATA/133 Hard disk drive

Models: HDS724040KLAT80



Introduction

The Hitachi Deskstar 7K400 is ideal for high performance desktop users. This drive features a capacity of 400 GB and a rotational speed of 7200 RPM. Average seek time is 8.5 ms. The Hitachi Deskstar 7K400 combines new and proven technologies to greatly enhance system performance and capacity.

Applications

- Advanced desktop and audio/video
- Low-cost routers
- Switches
- Video editing

Features

- Formatted capacity of 400GB
- Rotational speed 7200 RPM
- Ultra ATA/133 interface
- Self Diagnostics on Power On and resident diagnostics
- Operating shock—No data loss occurs with a 55 G half-sine shock pulse of 2 ms duration
- Idle power consumption of 9.0W
- Circuits and motors optimized to save power and reduce system temperature
- 8192 KB (upper 271 KB for firmware)
- Media transfer rates: 757 Mb/s
- Typical seek time(read): 8.5 ms
- Average latency: 4.17 ms
- Complies with ATA 7 specification
- Fluid Dynamic Bearing and tri-laminate top cover

Advantages

- Supports higher quality digital audio/video storage, superior digital content creation capabilities, and significantly faster processing
- Optimizes system performance
- Protection for drive mishandling
- Increased reliability
- Lower system power supply and cooling requirements
- Extending system life and reliability
- Fast access to data
- Improved throughput
- Lower acoustics

Connectors

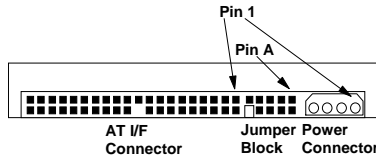

The DC power connector is designed to mate with AMP p/n 1-480424-0 using AMP strip pins (p/n 350078-4), loose piece pins (p/n 61173-4), or their equivalents.

Note: The AT signal connector is a 40-pin connector.

Cabling

The length of the cable from the host system to the drive must not exceed 18 inches.

For systems operating with Ultra DMA mode 3, 4, or 5, the 80-conductor ATA cable assembly must be used.

Jumper block

Jumper pin letter designations

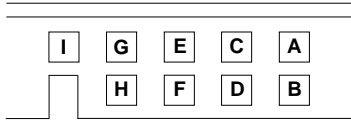

A jumper attaches two pins together to configure the drive for the proper mode of operation.

Jumper settings

16 head logical architecture

Master active*	A-B and G-H
Slave active	A-B and C-D
Cable Select	A-B and E-F
Master/Slave present	E-F and G-H
Reserved	I

15 head logical architecture

Master active	A-C and G-H
Slave active	A-C
Cable select	A-C and E-F
Master/Slave present	A-C, E-F & G-H
Reserved	I

All other jumper settings are reserved. Do not make other settings!

*Shipping default

DC power requirements

Damage to the drive electronics may result if the power supply cable is connected or disconnected while the power is on. There is no special power on/off sequencing required. The following voltage specification is applied at the power connector of the drive.

Input voltage (Volts)	During run and spin up (Volts)	Absolute max spike voltage
+5	5 ± 5%	7 ¹
+12	12 +10% -8%	15 ¹

¹Power supply voltage spikes in excess of the maximum values specified in the table may damage the drive electronics.

Power supply current

	mA RMS		Total Watts
	+5 V	+12V	
400 GB model			
Idle avg	350	600	9.0
Low RPM idle	200	280	4.4
Start up-max	1100	2000	—
RND R/W peak	1420	1350	—
RND R/W avg ²	560	850	13.0
Standby avg	150	20	1.0
Sleep avg	100	20	0.7

¹ Random seeks at 40% duty cycle

² Seek duty = 30%, W/R duty = 45%, Idle Duty = 25%

Power supply generated ripple

Output (V)	Maximum (mV p-p)	Freq. range (MHz)
+5	100	0-10
+12	150	0-10

Hot Plug/Unplug support

Hot plugging/unplugging is not allowed. Damage to the drive electronics may result if the power supply cable is connected or disconnected while power is being applied to the drive.

Data organization (logical)

Number of heads	16
Sectors/track	63
Number of cylinders	16,383

Capacity (GB)	Total logical data bytes
400	400,088,457,216

Electromagnetic compatibility

When installed in a suitable enclosure and exercised with a random accessing routine at the maximum data rate the hard disk drive meets the following worldwide EMC requirements listed below:

- United States Federal Communications Commission (FCC) Rules and Regulations (Class B), Part 15.
- European Economic Community (EEC) directive number 76/889 related to the control of radio frequency interference and the Verband Deutscher Elektrotechniker (VDE) requirements of Germany (GOP).

Environment

Operating conditions

Temperature	5 to 55°C ¹
Relative humidity (noncondensing)	8 to 90%RH
Maximum wet bulb temperature (noncondensing)	29.4°C
Maximum temperature gradient	15°C/hour
Altitude	-300 to 3048 m

¹The system is responsible for providing sufficient air movement to maintain a surface temperature below 60°C at the center of the top cover of the drive.

Non operating conditions

Temperature	-40 to 65°C
Relative humidity (noncondensing)	5 to 95%RH
Maximum wet bulb temperature (noncondensing)	35°C
Altitude	-300 to 12,000m

Operating shock

The drive meets the following criteria while operating in respective conditions described in the list below.

- No error occurs with a 10 G half-sine shock pulse of 11 ms duration in all models.
- No data loss occurs with a 30 G half-sine shock pulse of 4 ms duration in all models.
- No data loss occurs with a 55 G half-sine shock pulse of 2 ms duration in all models.

The shock test consists of ten shocks inputs in each axis and in each direction for a total of 60. There must be a delay between shock pulses that is long enough to allow the drive to complete all of the necessary error recovery procedure.

Nonoperating shock

The drives will operate with no degradation of performance after being subjected to a shock pulses with the following characteristics. The tests involved trapezoidal and sinusoidal shock wave.

Trapezoidal shock wave

- The approximate shape of the pulse is square (trapezoidal).
- Approximate rise and fall time of pulse = 1 ms.

- Average acceleration level = 50 G. (Average response curve value during the time following the 1 ms rise time and before the 1 ms fall with a time duration of 11 ms)
- Minimum velocity change equals 4.23 m/s.

Sinusoidal shock wave

The shape is approximately a half-sine pulse. The following table shows the maximum acceleration level and duration.

	Acceler- ation level (G)	Duration (ms)
400 GB	75	11
	300	2

Rotational shock

No data loss is incurred with the following rotational shocks applied around the axis of the actuator pivot:

- 30,000 rad/s² for a duration of 1 ms
- 20,000 rad/s² for a duration of 2 ms

Acoustics

The upper limit criteria of the octave sound power levels are given in Bels relative to one pico watt and are shown below. The measurement method is in accordance with ISO7779.

400 GB model

Mode	Typical (Bel)	Max. (Bel)
Idle	3.1	3.5
Operating		
Performance seek mode	3.5	3.8
Quiet seek mode	3.3	3.6



ATTENTION: The drive must be protected against electrostatic discharge especially when being handled. The safest way to

avoid damage is to put the drive in an anti-static bag before ESD wrist straps are removed.

Drives must be shipped in approved containers. Severe damage can be caused to the drive if the packaging does not adequately protect against the shock levels induced when a box is dropped. Consult your Hitachi Global Storage Technologies representative if you do not have an approved shipping container.

Command descriptions

The following commands are supported by the drive:

Commands	(Hex)	P
Check Power Mode	E5	3
Check Power Mode*	98	3
Execute Device Diagnostic	90	3
Flush Cache	E7	3
Format Track	50	2
Identify Device	EC	1
Idle	E3	3
Idle*	97	3
Idle Immediate	E1	3
Idle Immediate*	95	3
Initialize Device Parameters	91	3
NOP	00	3
Read Buffer	E4	1
Read DMA (retry)	C8	4
Read DMA (no retry)	C9	4
Read DMA Queued	C7	5
Read Long (retry)	22	1
Read long (no retry)	23	1
Read Multiple	C4	1
Read Native Max Address	F8	3
Read Sectors (retry)	20	1
Read Sectors (no retry)	21	1
Read Verify Sectors (retry)	40	3
Read Verify Sectors (no retry)	41	3
Recalibrate	1x	3
Security Disable Password	F6	2
Security Erase Prepare	F3	3
Security Erase Unit	F4	2
Security Freeze Lock	F5	3
Security Set Password	F1	2
Security Unlock	F2	2
Seek	7x	3
Service	A2	5
Set Features	EF	3
Set Max Address	F9	3
Set Multiple Mode	C6	3
Sleep	E6	3
Sleep*	99	3
SMART Disable Operations	B0	3
S.M.A.R.T. Enable/Disable Attribute Auto save	B0	3
S.M.A.R.T. Enable Operations	B0	3
S.M.A.R.T. Execute Off-line Data Collection	B0	3

S.M.A.R.T. Read Attribute Values	B0	1
S.M.A.R.T. Read Attribute Thresholds	B0	1
S.M.A.R.T. Return Status	B0	3
S.M.A.R.T. Save Attribute Values	B0	3
S.M.A.R.T. Read Log Sector	B0	1
S.M.A.R.T. Write Log Sector	B0	2
S.M.A.R.T. Enable/Disable Automatic Off-line Data Collection	B0	3
Standby	E2	3
Standby*	96	3
Standby Immediate	E0	3
Standby Immediate*	94	3
Write Buffer	E8	2
Write DMA (retry)	CA	4
Write DMA (no retry)	CB	4
Write DMA Queued	CC	5
Write Long (retry)	32	2
Write Long (no retry)	33	2
Write Multiple	C5	2
Write Sectors (retry)	30	2
Write Sectors (no retry)	31	2

Protocol

- 1 PIO data IN command
 - 2 PIO data OUT command
 - 3 Non data command
 - 4 DMA command
 - 5 DMA queued command
- + Vendor specific command

Note: Commands marked * are alternate command codes for previously defined commands

Signal definition

Pin	Signal	I/O	Type
01	RESET-	I	(2)
02	GND	-	-
03	DD7	I/O	(1)
04	DD8	I/O	(1)
05	DD6	I/O	(1)
06	DD9	I/O	(1)
07	DD5	I/O	(1)
08	DD10	I/O	(1)
09	DD4	I/O	(1)
10	DD11	I/O	(1)
11	DD3	I/O	(1)
12	DD12	I/O	(1)
13	DD2	I/O	(1)
14	DD13	I/O	(1)
15	DD1	I/O	(1)
16	DD14	I/O	(1)
17	DD0	I/O	(1)
18	DD15	I/O	(1)
19	GND	-	-
(20)	Key	-	-
21	DMARQ	O	(1)
22	GND	-	-
23	DIOW-(**)	I	(2)
24	GND	-	-
25	DIOR-(**)	I	(2)
26	GND	-	-
27	IORDY(**)	O	(1)
28	CSEL	I	(2)
29	DMACK-	I	(2)
30	GND	-	-
31	INTRQ	O	(1)
32			
33	DA1	I	(2)
34	PDIAG-	I/O	(3)
35	DA0	I	(2)
36	DA2	I	(2)
37	CS0-	I	(2)
38	CS1-	I	(2)
39	DASP-	I/O	(3)
40	GND	-	-

Notes:

Type:

- (1) 3-state
- (2) TTL
- (3) open-collector or open drain output

O – an output from the drive.

I - an input to the drive.

"I/O" designates an input/output common.

The signal lines marked with (**) are re-defined during the Ultra DMA protocol to provide special functions. These lines change from the conventional to special definitions at the moment the Host decides to allow a DMA burst if the Ultra DMA transfer mode was previously chosen by means of SetFeatures. The Drive becomes aware of this change upon assertion of the DMACK- line. These lines revert back to their original

definitions upon the deassertion of DMACK– at the termination of the DMA burst. See the table below.

Ultra DMA definitions

	Special definition (for Ultra DMA)	Conventional definition
Write	DDMARDY–	IORDY
	HSTROBE	DIOR–
	STOP	DIOW–
Read	HDMARDY –	DIOR–
	DSTROBE	IORDY
	STOP	DIOW–

Mechanical data

Height	25.4 mm ± 0.4
Width	101.6 mm ± 0.4
Length	146.0 mm ± 0.6
<hr/>	
Weight (maximum)	700 grams

Mounting

The drive will operate in all axes (six directions). Performance and error rate will stay within specification limits if the drive is operated in the other permissible orientations from which it was formatted.

For reliable operation the drive must be mounted in the system securely enough to prevent damage from excessive motion or vibration during seek operation or spindle rotation, using appropriate screws or equivalent mounting hardware.

Drive level vibration test and shock test are to be conducted with the drive mounted to the table using the bottom four screws.

Mounting holes

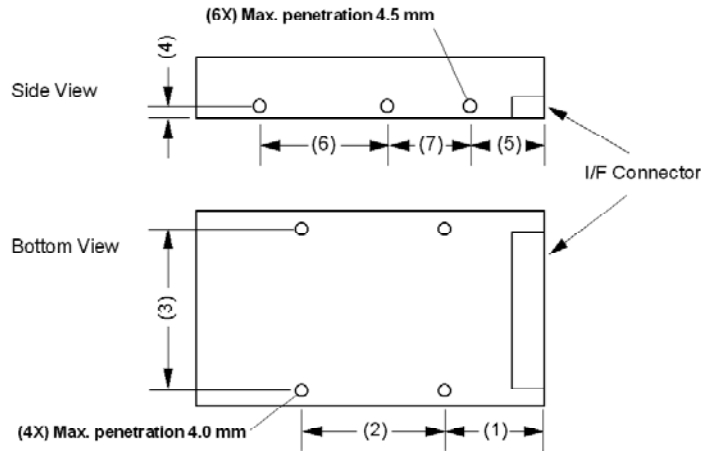

Dimension reference number	(1)	(2)	(3)	(4)	(5)	(6)	(7)
Dimension (mm)	41.28 ± 0.5	44.45 ± 0.2	95.25 ± 0.2	6.35 ± 0.2	28.5 ± 0.5	60.0 ± 0.2	41.6 ± 0.2

Mounting screw thread count = 6-32 UNC

Notes: Recommended screw torque to be applied to mounting screws is 0.6–1.0 Nm (6–10 kg-cm).

Mechanical dimensions

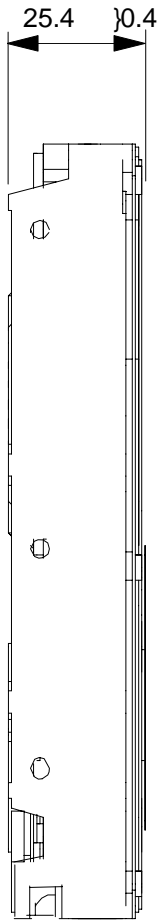

LEFT

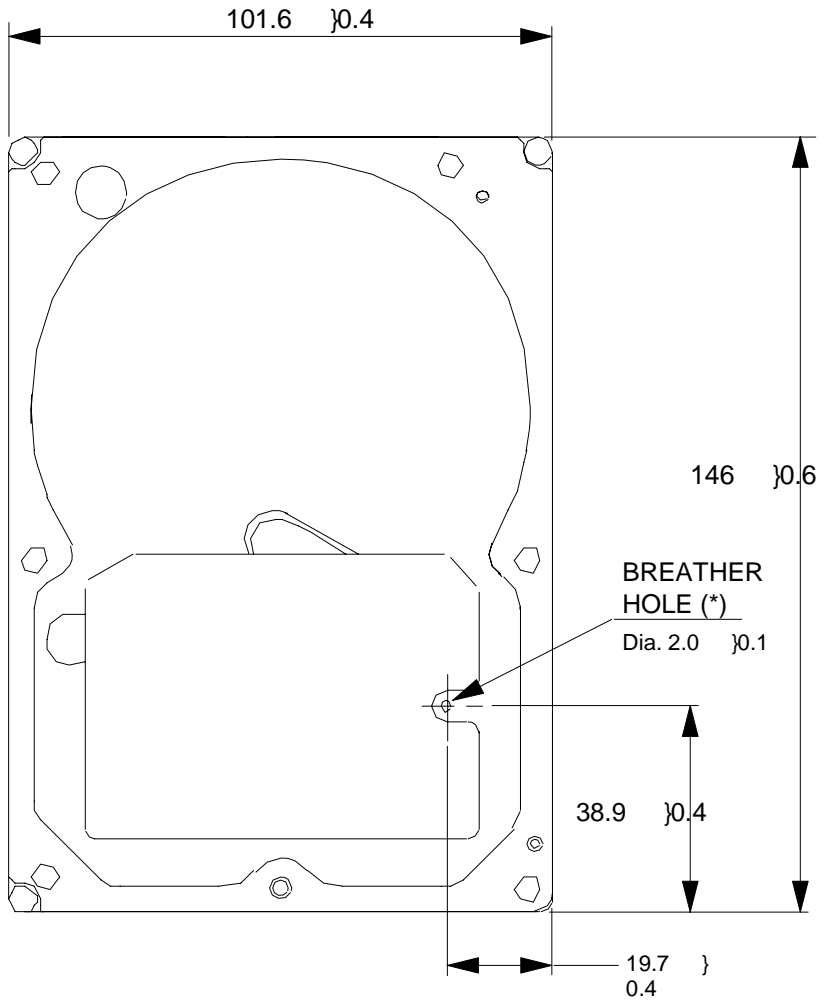

FRONT

*** DO NOT BLOCK THE BREATHER HOLE.**

© Copyright Hitachi Global Storage Technologies

Hitachi Global Storage Technologies
5600 Cottle Road
San Jose, CA 95193

Produced in the United States

8/04

All rights reserved Deskstar™ is a trademark of Hitachi Global Storage Technologies.

Microsoft, Windows XP, and Windows are trademarks of Microsoft Corporation in the United States, other countries, or both.

Other product names are trademarks or registered trademarks of their respective companies.

References in this publication to Hitachi Global Storage Technologies products, programs or services do not imply that Hitachi Global Storage Technologies intends to make these available in all countries in which Hitachi Global Storage Technologies operates.

Product information is provided for information purposes only and does not constitute a warranty.

Information is true as of the date of publication and is subject to change. Actual results may vary.

This publication is for general guidance only. Photographs may show design models.

19 August 2004
