



Deskstar 3

DAQA-32160 and DAQA-33240

IBM OEM has introduced a new range of disk drives for the desktop personal computer marketplace. Available in two capacity points with AT interface, the drives provide excellent performance and reliability.

Applications

- Desktop personal computers
- Entry servers
- Entry workstations



Features

- **2160 and 3240MB formatted capacity (512 byte/sector)**
- **PIO and DMA data transfer modes - Bus transfer rates up to 16.6 MB/s**
- **Average seek time 9.4ms (Read). 9.5 (Write)**
- **5400 RPM**
- **96 KB adaptive sector buffer**
- **Industry standard mounting**
- **The drive can be mounted with any of its six surfaces facing down**
- **Advanced ECC on the fly (EOF)**
- **CHS and LBA addressing modes**
- **Power saving modes**
- **Robust design for EMC/RFI**
- **MR (Magneto Resistive) head technology**
- **No ID sector format**
- **S.M.A.R.T. function support**

Benefits

- *Range of capacities to meet the need for increasing storage requirements*
- *Fast interface data rates*
- *Fast access to data*
- *Fast data retrieval in single and multi-tasking applications*
- *Ease of installation*
- *Improved data throughput*
- *Flexibility to support most appropriate addressing*
- *Reduced power consumption*
- *Easy integration across multiple platforms*
- *High areal density, low component count*
- *More data stored per track, increased sustained data transfer rate*
- *High reliability and availability*

Connectors

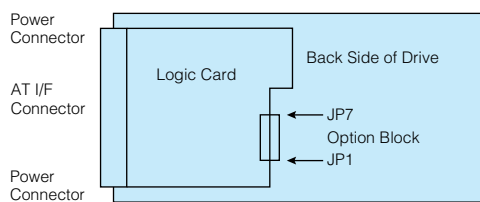
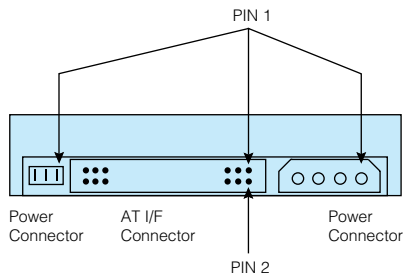

There is a choice of 2 power connections to this drive. One DC power connector is designed to mate with AMP part 1-480424 (using AMP pins P/N 350078-4). The other (3 pin) DC power connector is designed to mate with MOLEX 5480-03 (using MOLEX pins 5479). Equivalent connectors may be used. Pin assignments are shown below, as viewed from the end of the drive.

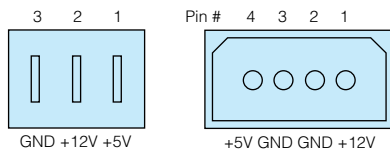

AT Signal Connector

The drive uses single-ended drivers and receivers. The connector is designed to mate with 3M part 3417-7000 or equivalent.



Note: It is intended that the hard disk should only be in electrical contact with the chassis of the PC at a designated set of mounting holes. Other electrical contact may degrade error rate performance. As a result of this it is recommended that there should be no metal contact to the hard disk drive except at the mounting holes or the side rails into which the mounting holes are tapped.

Option Block

Jumper Settings

Jumpers may be fitted to select the following options:

	Pin Numbers
MASTER active	1-2
SLAVE active	3-4
Cable sel	5-6
Reserved	7-8
Write cache	9-10 (Disabled with jumper)
Reserved	11-12
Reserved	13-14

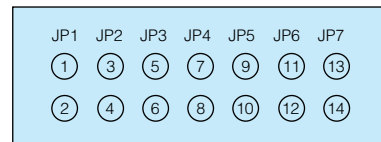

Write Cache Jumper

Write cache jumper is checked during the initial POR check.

Write cache is disabled when a jumper is fitted and in this case a 'Set features' command to switch Write cache 'on' or 'off' will be aborted by the drive.

Shipping Default Settings

MASTER is set to on (ie jumper on pins 1-2)

No other jumpers are fitted

Note: The jumper positions JP1, JP2, JP3 must not be selected concurrently.



PACKAGING: The drive must be protected against Electro-Static Discharge especially when being handled. The safest way to avoid damage is to put the drive in an anti static bag before ESD wrist straps etc are removed.

Drives should only be shipped in approved containers, severe damage can be caused to the drive if the packaging does not adequately protect against the shock levels induced when a box is dropped. Consult your IBM marketing representative if you do not have an approved shipping container.

Operating Environment

Operating Conditions

Temperature	5 to 55°C*
Relative Humidity	8 to 90% non-condensing
Maximum Wet Bulb	
Temperature	29.4°C non-condensing
Gradient Maximum	
Temperature	15°C/Hour
Altitude	– 300 to 3048m

Non Operating Conditions

Temperature	– 40 to 65°C
Relative Humidity	5 to 95% non-condensing
Maximum Wet Bulb	
Temperature	35°C non-condensing
Altitude	– 300 to 12,000m

Note: * The system is responsible to provide sufficient air movement to maintain surface temperature below 60°C at the center of the top cover of the drive.

Operating Shock

The hard disk drive meets the following criteria while operating in respective conditions described below. There must be a delay between shock pulses, long enough to allow the drive to complete all necessary error recovery procedure.

<i>No errors</i>	5G, 11ms half-sine shock pulse
<i>No data loss, seek errors or permanent damage</i>	10G, 11ms half-sine shock pulse
<i>No data loss or permanent damage</i>	15G, 5 ms half-sine shock pulse
	30G, 4 ms half-sine shock pulse

Non-Operating Shock

The drive withstands without damage or degradation of performance, a 75G half-sine wave shock pulse of 11ms duration on six sides when heads are parked. (When power is not applied to the unit the heads are automatically located in the parked position). Above specification is for shocks applied in each direction of the drives three mutually perpendicular axis, one axis at a time.

Operating Vibration

Due to the complexity of this subject we recommend that users contact the IBM technical support group representative to discuss how to perform the necessary measurements if they believe this to be an area which requires evaluation.

DC Power Requirement

The following voltage specifications apply at the drive power connector. Damage to the drive electronics may result if the power supply cable is connected or disconnected while power is being applied to the drive (No hot plug/unplug is allowed). There is no special power on/off sequencing required.

Input Voltage

+5 Volts Supply	5V (+/-5% during run and spin up) ¹
+12 Volts Supply	12V (+10%, -8% during run and spin up) ²

1: To avoid damage to the file electronics 5V, power supply voltage spikes must not exceed 7V.

2: To avoid damage to the file electronics 12V, power supply voltage spikes must not exceed 15V.

Power Supply Current

(All values in Amps.)	+5Volts Pop Mean	+12Volts Pop Mean
Idle average	0.15	0.16/0.21 (A/B ³)
Idle ripple (peak to peak)	0.30	0.30
Seek peak ¹	0.35	0.90
Seek average ¹	0.19	0.27/0.31 (A/B ³)
Start up (max)	0.46	1.10
Random R/W peak ²	0.50	0.90
Random R/W average ²	0.30	0.26/0.30 (A/B ³)
Standby/Sleep average	0.10	0.01

1: Random Seeks at 40% duty cycle.

2: Seek duty = 30%, W/R duty = 45%, Idle duty = 25%.

³ A/B show that A is for DAQA-32160 and B is for DAQA-33240.

Power Supply Generated Ripple as seen at file power connector.

	Maximum	Notes
+5V DC	100mV pp	0 – 10 MHz
+12V DC	150mV pp	0 – 10 MHz

During file start up and seeking, 12 volt ripple is generated by the file (referred to as dynamic loading).

If several files have their power daisy chained together then the power supply ripple plus other file's dynamic loading must remain within the regulation tolerance of +10/–8%. A common supply with separate power leads to each file is a more desirable method of power distribution.

To prevent external electrical noise from interfering with the file's performance, the file must be held by four screws in a user system frame which has no electrical level difference at the four screws position, and has less than +/- 300 millivolts peak to peak level difference to the file power connector ground.

Cabling

The maximum cable length from the Host system to the drive, plus the circuit pattern length inside the Host systems, must not exceed 18 inches (45.7cm).

For higher data transfer application (>8.3MB/sec) the cable length should be shorter than 18 inches (45.7cm) since data transfer characteristics depends on the driver circuits of the system and hard drive, and or cabling.

Signal Definition

The pin assignments of interface signals are listed as follows:

PIN	Signal	I/O	PIN	Signal	I/O
01	-RESET	I	02	GND	
03	DD07	I/O	04	DD08	I/O
05	DD06	I/O	06	DD09	I/O
07	DD05	I/O	08	DD10	I/O
09	DD04	I/O	10	DD11	I/O
11	DD03	I/O	12	DD12	I/O
13	DD02	I/O	14	DD13	I/O
15	DD01	I/O	16	DD14	I/O
17	DD00	I/O	18	DD15	I/O
19	GND		(20)	Key	
21	DMARQ	O	22	GND	
23	-DIOW	I	24	GND	
25	-DIOR	I	26	GND	
27	IORDY	O	28	CSEL	I
29	-DMACK	I	30	GND	
31	INTRQ	O	32	-HIOCS16	O
33	DA01	I	34	-PDIAG	I/O
35	DA00	I	36	DA02	I
37	-CSO	I	38	-CS1	I
39	-DASP	I/O	40	GND	

Note:

- "O" designates an output from the Drive.
- "I" designates an input from the Drive.
- "I/O" designates an input/output common.

Interface

The interface conforms to the working document of information technology – AT Attachment–3 Interface (ATA–3) revision 6 dated on October 26 1995 with following deviations.

BBK (Bad Block)

Bit 7 of Error Register is supported as BAD BLOCK bit. This bit will be set when BAD BLOCK is reported on Read commands.

Check Power Mode

CHECK POWER MODE command returns FFh to Sector Count Register when the device is in Idle mode. This command does not support 80h as the return value.

Sleep mode

During Sleep mode the drive will be activated by any command, including, but not limited to, a soft reset.

Hard Reset

Hard Reset response is identical to Soft Reset response with the following exception:

When drive is set as a SLAVE it will activate -DASP line to indicate it is present.

Data Organisation

Description	DAQA-32160	DAQA-33240
Physical Layout		
Label Capacity (MB)	2160	3240
Bytes per Sector	512	512
Sectors per Track	117-184	117-184
Number of heads	4	6
Number of disks	2	3
Logical Layout¹		
Number of Heads	16	16
Number of Sectors/Track	63	63
Number of Cylinders	4200	6296
# of Sectors	4233600	6346368
Total logical Data Bytes	2167603200	3249340416

- 1: Logical layout describes imaginary HDD parameters which are used to access customer data on the disk drive. Logical layout to Physical layout (ie. actual Head, Sector) translation is done automatically in the HDD. Default setting can be obtained by issuing IDENTIFY DRIVE command.

Command Description

The following Commands are supported by the Drive:

Commands	(Hex)
Check Power Mode	(E5)
Check Power Mode*	(98)
Execute Drive Diagnostics	(90)
Format Track	(50)
Identify Drive	(EC)
Identify Drive DMA	(EE)
Idle	(E3)
Idle*	(97)
Idle Immediate	(E1)
Idle Immediate*	(95)
Initialise Drive Parameters	(91)
Read Buffer	(E4)
Read DMA (retry)	(C8)
Read DMA (no retry)	(C9)
Read Long (retry)	(22)
Read Long (no retry)	(23)
Read Multiple	(C4)
Read. Sectors (retry)	(20)
Read Sectors (no retry)	(21)
Read Verify Sectors (retry)	(40)
Read Verify Sectors (no retry)	(41)
Recalibrate	(1X)
Seek	(7X)
Set Features	(EF)
Set Multiple	(C6)
Sleep	(E6)
Sleep*	(99)
Smart Function Set	(BO)
Standby	(E2)
Standby*	(96)
Standby Immediate	(EO)
Standby Immediate*	(94)
Write Buffer	(E8)
Write DMA (retry)	(CA)
Write DMA (no retry)	(CB)
Write Long (retry)	(32)
Write Long (no retry)	(33)
Write Multiple	(C5)
Write Sectors (retry)	(30)
Write Sectors (no retry)	(31)

* Alternate command codes for previous defined commands.

Electromagnetic Compatibility

The drive meets the following EMC requirements when installed in the user system and exercised with a random accessing routine at maximum data rate:

United States Federal Communication Commission (FCC) Rules and Regulations Part 15, subject J – Computer Devices “Class B Limits”.

European Economic Community (ECC) directive #76/889 related to the control of radio frequency interference and the Verband Deutscher Elektrotechniker (VDE) requirements of Germany (GOP).

Registers (Primary Channel Addresses)

Address	Input Register	Output Register
1F0h	Data	Data
1F1h	Error	Features
1F2h	Sector Count	Sector Count
1F3h	Sector Number *LBA bits 0-7	Sector Number *LBA bits 0-7
1F4h	Cylinder Low *LBA bits 8-15	Cylinder Low *LBA bits 8-15
1F5h	Cylinder High *LBA bits 16-23	Cylinder High *LBA bits 16-23
1F6h	Drive/Head *LBA bits 24-27	Drive/Head *LBA bits 24-27
1F7h	Status	Command
3F6h	Alternate Status	Device Control
3F7h	Drive Address	Not Used

The host uses the register interface to communicate to and from the drive. The registers are accessed through the host port addresses shown.

The host should not read or write any registers when the Status Register BSY bit = 1.

Note: * Meaning of Register contents when LBA addressing mode used.

Mechanical Data

Dimensions

Height	25.4 ± 0.4mm
Width	101.6 ± 0.4mm
Length	146.0 ± 0.6mm
Weight	610g maximum

The maximum allowable penetration of the mounting screws is 1 3.5mm 2 6mm.

Outline Dimensions

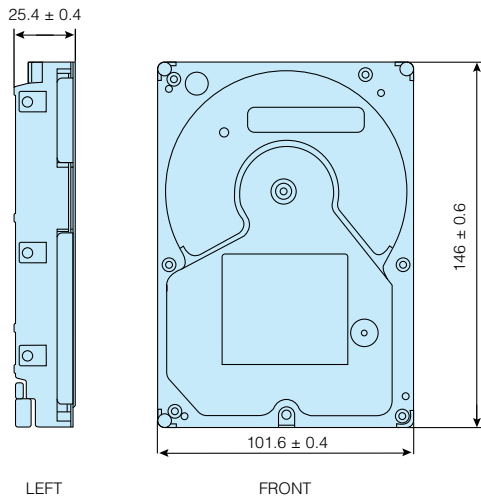

IBM OEM Europe
 PO Box 6
 Langstone Road
 Havant
 Hampshire
 PO9 1SA
 United Kingdom
 Telephone: (44) 1705 486363

IBM Corporation
 Storage Systems Division
 5600 Cottle Road
 San Jose, CA 95193
 (408) 256-8000

Japan Headquarters: (81) 466-45-1384

Asia-Pacific Headquarters: (65) 320-1503

Internet access at:
<http://www.storage.ibm.com/storage/oem/menu1.htm>

Registered in England: No. 741598
 Registered Office: PO Box 41, North Harbour,
 Portsmouth, Hampshire PO6 3AU.

UK company-wide registration to ISO9001.
 Certificate number FM12587.

IBM is the registered trademark of International
 Business Machines Corporation.

AMP is a trademark of AMP Incorporated
 Molex is a trademark of Molex Incorporated
 DATA MATE is a trademark of AMP Incorporated

Other company, product and service names may be
 trademarks or service marks of others.

Printed in England by Cedar Colour Limited

© International Business Machines Corporation 1996.

This data sheet is not a substitute for the full
 production specification, which should be used
 when detailed information is required.

Product Description data represents IBM's design
 objectives and is provided for comparative
 purposes; actual results may vary based on a
 variety of factors. This product data does not
 constitute a warranty. Questions regarding IBM's
 warranty terms or methodology used to derive this
 data should be referred to your IBM OEM
 representative. Data subject to change without notice.

Date: 9th July 1996

Distributor:

Mounting Holes

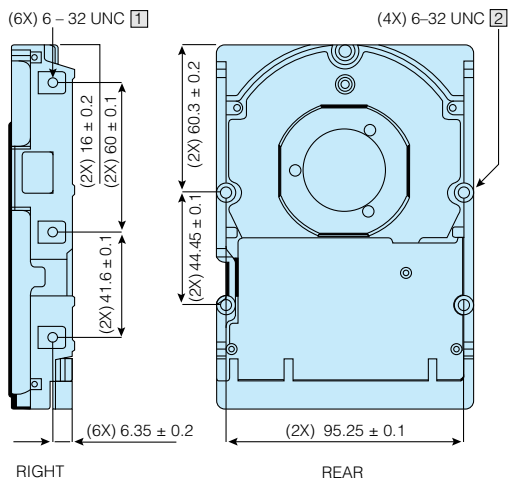

The recommended mounting screw torque is
 8 ± 2.0 [KgF cm]

Connector Locations

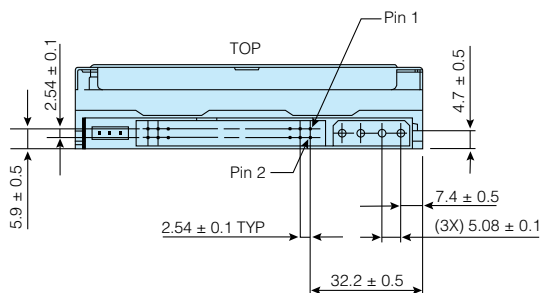

IBM OEM Storage Product Integration Information

Addendum to DAQA-3XXXX Torque Settings

DAQA-3XXXX

Please note that the Data Sheet for DAQA-3XXXX there is an error under the diagram for mounting holes on the final page.

At present the recommended mounting screw torque reads:-

3+/-0.5 [KgF.cm]

The recommended mounting screw torque should read:-

8+/-2.0 [KgF.cm]

All trademarks are acknowledged. This information is provided for the use of OEM Manufacturers attaching IBM disk drives and is believed to be accurate, but is supplied without guarantee.