



Product summary

Deskstar 37GP

ATA/IDE



Models: DPTA-353750 DPTA-353000
 DPTA-352250 DPTA-351500

Introduction

IBM's latest Deskstar drives are ideal for high-performance desktop users. With capacities of up to 37GB and a rotational speed of 5400RPM users have access to the highest capacities and performance in the industry.

Applications

- High performance Desktop personal computers
- Entry servers
- Entry workstations
- Multimedia applications
- Video editing

Features

- 37.5GB, 30GB, 22.5GB & 15GB formatted capacities
- Industry standard interface
 - PIO Mode 4 rates up to 16.6MB/sec
 - Ultra DMA/66 rates up to 66.6MB/sec
- 20.4 - 10.9 MB/sec sustained data transfer rate
- Rotational speed 5,400 RPM
- Average seek time 8.5ms (read)
- Average latency 5.56ms
- 1961KB OR 425KB¹ segmented sector buffers
- ECC on-the-fly
- Power saving modes
- S.M.A.R.T. function support
- Drive Fitness Test (DFT) technology
- Transparent Defect Management with ADR
- Security function support

Benefits

- Range of capacities to meet the need for increasing storage requirements
- Popular interface with excellent performance
- Excellent data rate across disk surface
- Fast access to data
- Fast access to data and improved throughput
- High reliability
- Reduced power consumption
- Protection of user data
- No user intervention required; defects reallocated on the fly
- Password protection for sensitive data

¹ 425KB on 352250 and 351500

Cabling

The maximum cable length from the host system to the drive must not exceed 18 inches.

For systems operating with Ultra DMA mode 3 or 4, the 80 conductor ATA cable assembly (SFF-8049) must be used.

Connectors

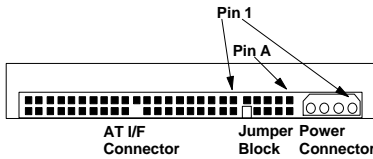

The DC power connector is designed to mate with AMP (part 1-480424-0) using AMP pins (part 350078-4) strip or (part 61173-4) loose piece, or their equivalents. Pin assignments are shown below.

Note: The AT signal connector is a 40 pin connector.

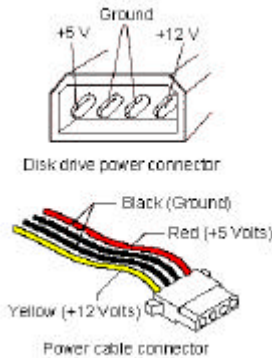

Jumper block

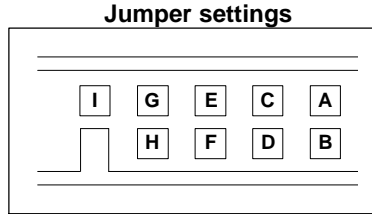

Jumper pins are located between power pins and AT interface pins. Pins A through I are prepared for jumper setting.

16 head logical architecture

Master active*	A-B and G-H
Slave active	A-B and C-D
Cable Select	A-B and E-F
Master/Slave present	E-F and G-H
Reserved	I

15 head logical architecture

Master active	A-C and G-H
Slave active	A-C
Cable select	A-C and E-F
Master/Slave present	A-C, E-F, and G-H
Reserved	I

All other jumper setting patterns are reserved. *Do not make other settings!*

*Shipping default

DC power requirements

Connection to the product should be made in isolated secondary circuits (SELV). The following voltage specification is applied at the power connector of the drive. There is no special power on/off sequencing required.

	Power supply current			
	353750 & 353000		352250 & 351500	
	+5 V rms	+12 V rms	+5 V rms	+12 V rms
Idle average	0.3	0.3	0.3	0.2
Idle ripple (peak to peak)	0.3	0.5	0.3	0.3
Seek peak	0.5	1.7	0.5	1.5
Seek average ¹	0.4	0.5	0.4	0.4
Start up (max.)	0.9	2.0	0.9	1.6
RND R/W peak	1.0	1.7	1.0	1.5
RND R/W average ²	0.6	0.5	0.6	0.3
Standby average	0.2	0.008	0.2	0.009
Sleep average	0.08	0.01	0.08	0.01

¹ Random seeks at 40% duty cycle.

² Seek duty = 30%, W/R duty = 45%, Idle Duty = 25%.

Data organization (logical)

	DPTA-	353750	353000	352250	351500
Number of heads		16*/15	16*/15	16*/15	16*/15
Sectors/track		63	63	63	63
Number of cylinders		16,383	16,383	16,383	16,383
Customer usable data bytes		37,509,857,280	30,003,240,960	22,520,365,056	15,020,457,984

* Shipping default

Power supply generated ripple

	Maximum	Notes
+5V DC	100 [mV pp]	0-10 [MHz]
+12V DC	150 [mV pp]	0-10 [MHz]

Hot Plug/Unplug support

Hot plugging/unplugging is not allowed because damage to the file electronics may result if the power supply cable is connected or disconnected while power is being applied to the drive.

Electromagnetic compatibility

The drive, when installed in a suitable enclosure and exercised with a random accessing routine at maximum data rate, meets the worldwide EMC requirements listed below.

IBM will provide technical support to assist users in complying with the EMC requirements.

- United States Federal Communications Commission (FCC) Rules and Regulations (Class B), Part 15.
- European Economic Community (EEC) directive number 76/889 related to the control of radio frequency interference and the Verband Deutscher Elektrotechniker (VDE) requirements of Germany (GOP).

CE Mark

The Deskstar 37GP complies with EC directive 879/336/EEC. CE mark for the certification is indicated on the drive label.

C-Tick Mark

The Deskstar 37GP complies with the following Australian EMC standard: Limits and methods of measurement of radio disturbance characteristics of information technology equipment, AS/NZS 3548:1995 CLASS-B.

Environment

Operating conditions

Temperature	5 to 55°C
Relative humidity	8 to 90%RH
Maximum wet bulb temperature	29.4°C
Maximum temperature gradient	15°C/hour
Altitude	-300 to 3048m

Non-operating conditions

Temperature	-40 to 65°C
Relative humidity	5 to 95%RH
Maximum wet bulb temperature	35°C
Maximum temperature gradient	15°C/hour
Altitude	-300 to 12,000m

Note: The system has to provide sufficient ventilation to maintain a surface temperature below 60[°C] at the center of the drive's top cover.

Operating shock

The drive meets the following criteria:

- No data loss with 10g 11msec half-sine shock pulse
- No data loss with 65G 2msec half-sine shock pulse

The shock pulses of each level are applied to the drive, ten pulses for each direction and for all three axes. There must be a minimum of 30 seconds delay between shock pulses. Input levels are measured on a base plate where the drive is attached with four screws.

Non-operating shock

The drive withstands the following half-sine shock pulse:

- No data loss with 75G 11msec
- No data loss with 200G 2msec

The shocks are applied for each direction of the drive for three mutually perpendicular axes and one axis at a time. Input levels are measured on a base plate where the drive is attached with four screws.

Rotational shock

The drive withstands the following rotational shock.

DPTA-352250 & 351500
No data loss with rotational shock 20,000 rad/s² 2ms applied around the axis of the actuator pivot.

DPTA-353750 & 353000
No data loss with rotational shock 15,000 rad/s² 2ms applied around the axis of the actuator pivot.

Note: The actuator is automatically locked at power-off to keep the heads on a landing zone

Acoustics

The upper limit criteria of the A-weighted sound power levels are given in Bel relative to one pico watt and are shown in the following table. The measurement method is in accordance with ISO7779.

A-weighted sound power level [Bel]

DPTA-352250 & 351500		
Mode	typical	max
Idle	3.3	3.6
Operating	4.2	4.5

DPTA-353750 & 353000		
Mode	typical	max
Idle	3.4	3.7
Operating	4.2	4.5

Command descriptions

The following commands are supported by the drive:

Commands	(Hex)	P
Check Power Mode	E5	3
Check Power Mode*	98	3
Execute Device Diagnostic	90	3
Flush Cache	E7	3
Format Track	50	2
Identify Device	EC	1
Idle	E3	3
Idle*	97	3
Idle Immediate	E1	3
Idle Immediate*	95	3
Initialize Device Parameters	91	3
NOP	00	3
Read Buffer	E4	1
Read DMA (retry)	C8	4
Read DMA (no retry)	C9	4
Read DMA Queued	C7	5
Read Long (retry)	22	1
Read long (no retry)	23	1
Read Multiple	C4	1
Read Native Max LBA/CYL	F8	3
Read Sectors (retry)	20	1
Read Sectors (no retry)	21	1
Read Verify Sectors (retry)	40	3
Read Verify Sectors (no retry)	41	3
Recalibrate	1x	3
Security Disable Password	F6	2
Security Erase Prepare	F3	3
Security Erase Unit	F4	2
Security Freeze Lock	F5	3
Security Set Password	F1	2
Security Unlock	F2	2
Seek	7x	3
Service	A2	5
Set Features	EF	3
Set Max LBA/CYL	F9	3

Set Multiple Mode	C6	3
Sleep	E6	3
Sleep*	99	3
SMART Disable Operations	B0	3
SMART Enable/Disable Attribute Autosave	B0	3
SMART Enable Operations	B0	3
SMART Execute Off-line Data Collection	B0	3
SMART Read Attribute Values	B0	1
SMART Read Attribute Thresholds	B0	1
SMART Return Status	B0	3
SMART Save Attribute Values	B0	3
SMART Enable/Disable Automatic Off-line Data Collection	B0	3
Standby	E2	3
Standby*	96	3
Standby Immediate	E0	3
Standby Immediate*	94	3
Write Buffer	E8	2
Write DMA (retry)	CA	4
Write DMA (no retry)	CB	4
Write DMA Queued	CC	5
Write Long (retry)	32	2
Write Long (no retry)	33	2
Write Multiple (retry)	C5	2
Write Sectors (retry)	30	2
Write Sectors (no retry)	31	2

Protocol

- 1 : PIO data IN command
- 2 : PIO data OUT command
- 3 : Non data command
- 4 : DMA command
- 5 : DMA queued command
- + : Vendor specific command

Note: Commands marked * are alternate command codes for previously defined commands.



ATTENTION: The drive must be protected against electrostatic discharge especially when being handled. The safest way to avoid damage is to put the drive in an anti-static bag before ESD wrist straps are removed.

Drives should only be shipped in approved containers. Severe damage can be caused to the drive if the packaging does not adequately protect against the shock levels induced when a box is dropped. Consult your IBM representative if you do not have an approved shipping container

Signal definition

Pin	Signal	I/O
01	-RESET	I
02	GND	
03	DD07	I/O
04	DD08	I/O
05	DD06	I/O
06	DD09	I/O
07	DD05	I/O
08	DD10	I/O
09	DD04	I/O
10	DD11	I/O
11	DD03	I/O
12	DD12	I/O
13	DD02	I/O
14	DD13	I/O
15	DD01	I/O
16	DD14	I/O
17	DD00	I/O
18	DD15	I/O
19	GND	
(20)	Key	
21	DMARQ	O
22	GND	
23	-DIOW(*)	I
24	GND	
25	-DIOR(*)	I
26	GND	
27	IORDY(*)	O
28	CSEL	I
29	-DMACK	I
30	GND	
31	INTRQ	O
32	-HIOCS16	O
33	DA01	I
34	-PDIAB /-CBLID	I/O
35	DA00	I
36	DA02	I
37	-CS0	I
38	-CS1	I
39	-DASP	I/O
40	GND	

Notes:

1. "O" designates an output from the drive.
2. "I" designates an input to the drive.
3. "I/O" designates an input/output common.
4. The signal lines marked with (*) are redefined during the Ultra DMA protocol to provide special functions. If the Ultra DMA transfer mode was previously chosen via SetFeatures, these lines change from the conventional to special definitions at the moment the Host decides to allow a DMA burst. The drive becomes aware of this change upon assertion of the -DMACK line. These lines revert back to their original definitions upon the deassertion of -DMACK at the termination of the DMA burst.

	Special definition (for Ultra DMA)	Conventional definition
Write operation	-DDMARDY	IORDY
	HSTROBE	-DIOR
	STOP	-DIOW
Read operation	-HDMARDY	-DIOR
	DSTROBE	IORDY
	STOP	-DIOW

Mechanical data

Height	25.4mm ± 0.4
Width	101.6mm ± 0.4
Length	146.0mm ± 0.6
Weight (max)	
353750 & 353000	630 grams
352250 & 351500	580 grams

Mounting

The drive will operate in all axes (6 directions). The drive will operate within the specified error rates when tilted ± 5 degrees from these positions.

Performance and error rate will stay within specification limits if the drive is operated in the other permissible orientations from which it was formatted. Thus, a drive formatted in a horizontal orientation will be able to run vertically and vice versa.

The recommended mounting screw torque is 0.6 - 1.0 [Nm] (6-10 [Kgf.cm]).

The recommended mounting screw depth is 4 [mm] maximum for bottom and 4.5 [mm] maximum for horizontal mounting.

If an electrical screw driver is used for mounting screws, a Current Control Type Electrical Screw Driver should be used. A Mechanical Latch Type Electrical Screw Driver is not recommended because of the possibility of mechanical shock higher than specification value which may cause damage to the drive.

The system is responsible for mounting the drive securely enough to prevent excessive motion or vibration of the drive at seek operation or spindle rotation, using appropriate screws or equivalent mounting hardware.

Mechanical dimensions



Left

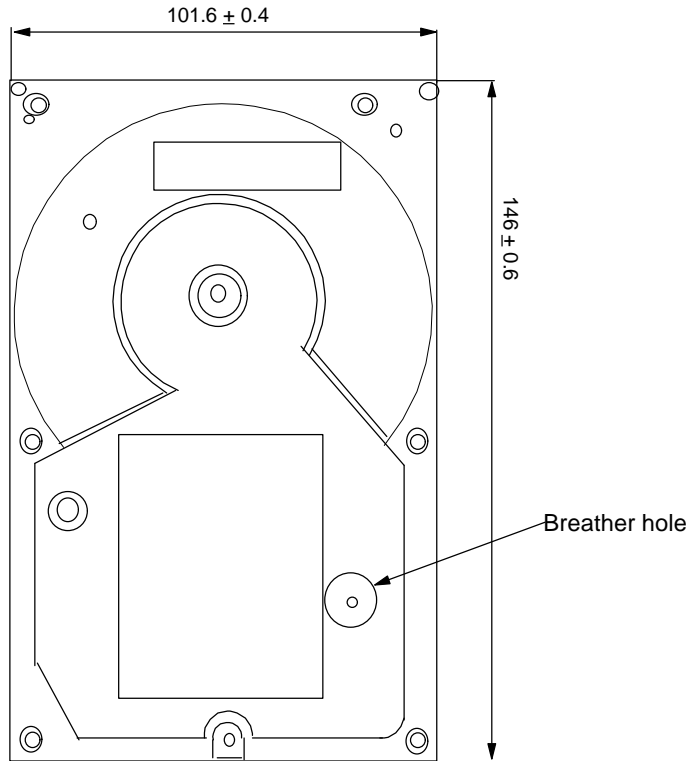

Top

Mounting hole locations

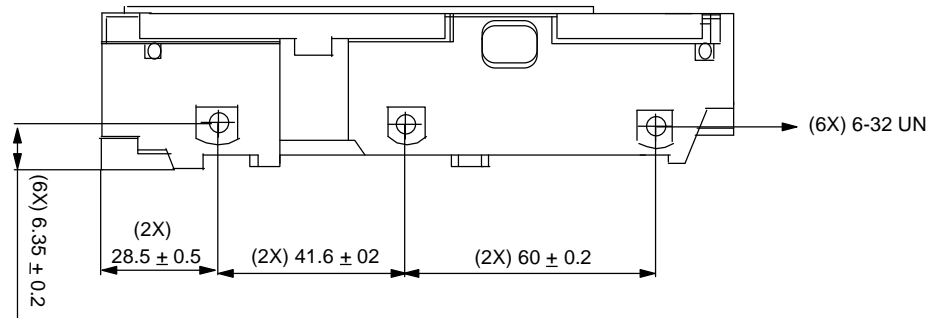

Right

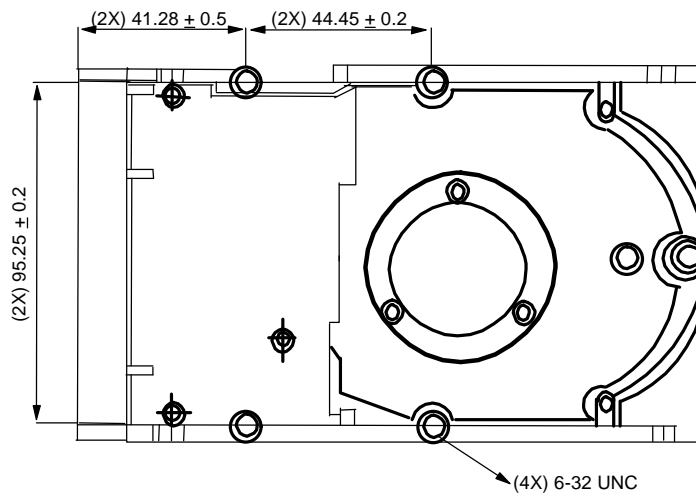

Bottom



© International Business Machines Corporation 1999

www.ibm.com/harddrive

IBM Hard Disk Drive Technical Support Center

Dept. WCN
3605 Highway 52 North
Rochester, MN 55901
Telephone: 888.IBM.5214 or 507.286.5825
Fax: 507.253.DRIVE
E-mail: drive@us.ibm.com

Singapore Technical Support Center

Telephone: (65)6418.9595 or 1800.418.9595
E-mail: drive@sg.ibm.com

IBM Storage Systems Division

5600 Cottle Road
San Jose, CA 95193
www.ibm.com/storage

Printed in the United States of America

07-99

All Rights Reserved

IBM, Drive-TIP, No-ID, and Predictive Failure Analysis are the registered trademarks of International Business Machines Corporation.

AMP is a trademark of AMP Incorporated.
DATA MATE is a trademark of AMP Incorporated.
Molex is a trademark of Molex Incorporated.

Other company, product, and service names may be trademarks or service marks of others.

Produced by the IBM Hard Disk Drive Technical Support Center.

OEM Hard Disk Drive Specifications for DPTA-3xxxxx
3.5-Inch Hard Disk Drive with ATA Interface, Rev. 2.1

This product summary is not a substitute for the full production specification, which should be used when detailed information is required.

Product Description data represents IBM's design objectives and is provided for comparative purposes; actual results may vary based on a variety of factors. This product data does not constitute a warranty. Questions regarding IBM's warranty terms or methodology used to derive this data should be referred to the IBM Hard Disk Drive Technical Support Center. Data subject to change without notice.

Date: 30 July 1999