

# Product summary

## Travelstar 10GT

### AT/IDE



Models: DCXA-210000  
DCXA-208100

IBM's latest 2.5 inch disk drives provide up to 10,050MB in a slim 12.5mm package. The latest GMR head technology, IBM's patented No-ID sector formatting, the S.M.A.R.T. function, advanced power saving modes, and IBM's "Load/unload heads" technology make the Travelstar 10GT particularly suited to the mobile computing market and multimedia applications.

#### Applications

- High performance portable computers
- Non-IT - process control/fax
- Removable/secure storage units

#### Features

- 8190/10050MB at 512 bytes/sector
- Enhanced IDE interface with Ultra-DMA data transfer - mode 2 (33.3MB/sec)
- PIO data transfer - mode 4 (16.6MB/sec)
- Shock 600G (2ms) non-operational
- Shock 125G (2ms) operational
- 69 to 118 Mbits/sec media data transfer rate
- Rotational speed 4,200 RPM
- Average seek time 12ms (read)
- Average latency 7.1ms
- Giant Magnetoresistive heads
- No-ID sector formatting
- PRML data channel
- 420KB segmented buffer with write cache
- Enhanced ECC On-The-Fly
- Adaptive power save control (0.65 Watt at idle state)
- Load/unload heads
- S.M.A.R.T. function
- Drive Fitness Test (DFT) technology

#### Benefits

- High capacity in slim 2.5 inch form factor
- Popular interface with excellent performance
- Robust design for portable computing applications
- Excellent data rate across disk surface
- Fast access to data
- High areal density, low component count
- More data stored per track, increased sustained data transfer rate
- Fast access to data and improved throughput
- High reliability
- Low power for battery powered applications
- Increased durability during power save modes and non-operation
- Protection of user data

**Electrical connector locations**

**Drive Address**

Jumper positions to determine the drive address are available at the interface connector. The diagram at the bottom of this page reflects jumper pin location.

When using Cable Selection, the drive address depends on the condition of pin 28 of the AT interface cable. If pin 28 is ground or low, the drive is a Master. If pin 28 is open or high level, the drive is a Slave.

**Cabling**

The maximum cable length from the host system to the drive plus the length of the circuit pattern in the host system shall not exceed 18 inches.

**AT Signal Connector**

The AT signal connector is designed to mate with Dupont part number 69764-044 or equivalent.

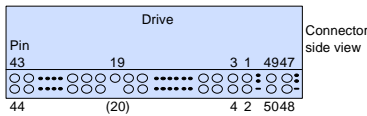

**Data organization**

DCXA	210000	208100
Head number	16	16
Sectors/track	63	63
Cylinder number	16,383	15,880
Sector size	512	512
Total customer usable data sectors	To be defined	To be defined
Total customer usable data bytes	10,050MB (To be defined)	8,190MB (To be defined)

**DC power requirements**

Nominal supply	+5 Volt
Power supply ripple (0 - 20 Mhz) <sup>1</sup>	100 mV p-p max
Tolerance <sup>2</sup>	± 5%
Supply wattage (+5.00V case)	Population mean (nominal condition)
Performance idle average <sup>3</sup>	1.85 W Typical
Active idle average	0.95 W Typical
Low power idle average	0.65 W Typical
Read <sup>4</sup>	2.1 W Typical
Write	2.2W Typical
Seek average <sup>5</sup>	2.3 W Typical
Standby	0.25 W Typical
Sleep	0.1 W Typical
Startup (maximum peak) <sup>6</sup>	4.7 W typical
(average from power on to ready)	3.3 W Typical
Supply rise time	7 - 100 ms

**Notes**

1. The maximum fixed disk ripple is measured at 5V input of the drive.
2. The disk drive shall not incur damage for an over voltage condition of +25% (maximum duration of 20 ms) on the 5 volt nominal supply.
3. The idle current is specified at an inner track.
4. The read/write current is specified based on three operations of 63 sector read/writes per 100msec.
5. The seek average current is specified based on three operations per 100msec.
6. The worst case operating current includes motor surge.



**ATTENTION:** The drive must be protected against electrostatic discharge especially when being handled. The safest way to avoid damage is to put the drive in an anti-static bag before ESD wrist straps are removed.

Drives should only be shipped in approved containers. Severe damage can be caused to the drive if the packaging does not adequately protect against the shock levels induced when a box is dropped. Consult your IBM representative if you do not have an approved shipping container

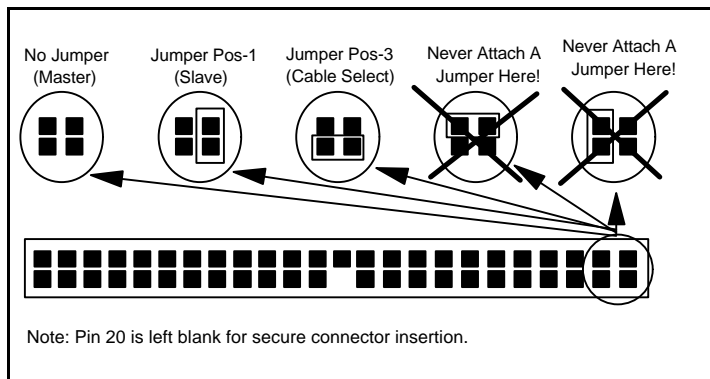

**Command descriptions**

The following commands are supported by the drive:

Command	Code (Hex)	Protocol
Check power mode	E5	3
Check power mode	98	3
Execute device diagnostic	90	3
Flush cache	E7	3
Format track	50	2
Format unit	F7	3+
Identify device	EC	1
Identify device DMA	EE	4
Idle	E3	3
Idle*	97	3
Idle immediate	E1	3
Idle immediate*	95	3
Initialize device parameters	91	3
Read buffer	E4	1
Read DMA (retry)	C8	4
Read DMA (no retry)	C9	4
Read long (retry)	22	1
Read long (no retry)	23	1
Read multiple	C4	1
Read native max address	F8	3
Read sectors (retry)	20	1
Read sectors (no retry)	21	1
Read verify sectors (retry)	40	3
Read verify sectors (no retry)	41	3
Recalibrate	1x	3
Security disable password	F6	2
Security erase prepare	F3	3
Security erase unit	F4	2
Security freeze lock	F5	3
Security set password	F1	2
Security unlock	F2	2
Seek	7x	3
Set features	EF	3
Set max LBA/CYL	F9	3
Set multiple mode	C6	3
Sleep	E6	3
Sleep*	99	3
SMART disable operation	B0	3
SMART enable/disable attribute autosave	B0	3
SMART enable operations	B0	3
SMART execute off-line immediate	B0	3
SMART read attribute	B0	1

values

SMART read attribute thresholds	B0	1
SMART return status	B0	3
SMART save attribute values	B0	3
Standby	E2	3
Standby*	96	3
Standby immediate	E0	3
Standby immediate*	94	3
Write buffer	E8	2
Write DMA (retry)	CA	4
Write DMA (no retry)	CB	4
Write long (retry)	32	2
Write long (no retry)	33	2
Write multiple	C5	2
Write sectors (retry)	30	2
Write sectors (no retry)	31	2
Write verify	3C	2

**Protocol**

- 1 PIO data IN command
  - 2 PIO data OUT command
  - 3 Non data command
  - 4 DMA command
  - + Vendor specific command
- Commands marked \* are alternate command codes for previously defined commands.

**Signal definition**

The pin assignments of interface signals are listed as follows:

Pin	Signal	I/O
1	-RESET	I
2	GND	
3	DD07	I/O
4	DD08	I/O
5	DD06	I/O
6	DD09	I/O
7	DD05	I/O
8	DD10	I/O
9	DD04	I/O
10	DD11	I/O
11	DD03	I/O
12	DD12	I/O
13	DD02	I/O
14	DD13	I/O
15	DD01	I/O
16	DD14	I/O
17	DD00	I/O
18	DD15	I/O
19	GND	
-20	Key	
21	DMARQ	O
22	GND	
23	-DIOW(*)	I
24	GND	
25	-DIOR(*)	I

26	GND	
27	IORDY(*)	O
28	CSEL	I
29	-DMACK	I
30	GND	
31	INTRQ	O
32	-IOCS16	O
33	DA01	I
34	-PDIAG	I/O
35	DA00	I
36	DA02	I
37	-CS0	I
38	-CS1	I
39	-DASP	I/O
40	GND	
41	+5V logic	power
42	+5V motor	power
43	GND	
44	RESERVE	

**Notes**

“O” designates an output from the drive.  
 “I” designates an input to the drive  
 “I/O” designates an input/output common.  
 “OD” designates Open-Drain output.  
 (\*) designates signal lines that are redefined during the Ultra DMA protocol to provide special functions. If the Ultra DMA transfer mode was previously chosen via SetFeatures, these lines change from the conventional to special definitions at the moment the Host decides to allow a DMA burst. The drive becomes aware of this change upon assertion of the -DMACK line. These lines revert back to their original definitions upon the deassertion of -DMACK at the termination of the DMA burst.

“Power” designates a power supply to the drive.

“Reserve” designates reserved pins which must be left unconnected.

	Special definition (for Ultra DMA)	Conventional Definition
Write operation	-DDMARDY	IORDY
	HSTROBE	-DIOR
	STOP	-DIOW
Read operation	-HDMARDY	-DIOR
	DSTROBE	IORDY
	STOP	-DIOW

### 5V power

There are two input pins for +5V power supply, “+5V Logic” and “+5V Motor”. “+5V Logic” is connected to the internal logic circuits and “+5V Motor” is connected to the spindle motor and motor driver.

“+5V Logic” can be turned on and off by an external switch circuit to reduce power consumption. In this mode, a voltage drop out due to the motor spin up current can be reduced by connecting the “+5V Motor” line directly into the system power source.

If the above power management option is used, all signal lines that will be electrically active in the host system while the drive is disconnected from the power line shall be isolated by Three-State line drivers. Internal leakage through the ESD protection circuit may bring the Least Positive Up Level (LPUL) of the logic signal below specifications.

Use both lines in parallel for regular drive application.

---

### Load/Unload heads

When used properly, the Load/Unload mechanism allows 300,000 cycles of starts and stops. The heads are unloaded by

invoking one of the following commands:

SOFT RESET  
STANDBY  
STANDBY IMMEDIATE  
SLEEP

It is also invoked as one of the idle modes. After a short period of inactivity the Adaptive Battery Life Extender power management will unload the heads to conserve energy. When the heads are unloaded, they rest in a small detent. To prevent the heads from being thrown off the ramp during angular acceleration, a bi-directional, normally open, mechanical latch engages with the actuator to keep it from turning in the head loading direction. This action causes a “rattle” sound to be heard which can be mistaken for loose parts.

---

### Adaptive Battery Life Extender

The Adaptive Battery Life Extender (ABLE-2) provides power saving without performance degradation. ABLE-2 technology automatically determines the correct time to start removing power from the drive electronics.

Most software and operating systems make use of a disk drive in bursts. The Travelstar drives monitor the commands which are sent from the host to detect patterns which indicate that a command sequence is finished by putting the drive into low overall power consumption and longer battery life with no loss in performance. If the host system changes the number or frequency of commands which it sends then the disk drive will adapt automatically to this new pattern.

This feature has three idle modes; Performance idle mode, Active idle mode, and Low Power idle mode.

---

### Operating modes

To provide the greatest flexibility of operation with optimum performance and power consumption, the drive has a number of operating modes. These are defined below.

#### Active mode

While in Active mode, the drive is performing a command, writing cached data to disk or filling a read ahead buffer.

#### Performance idle

During Performance idle, the drive is spinning but is not performing a command. It can respond immediately if a new command is received. The transition from active mode to Performance idle mode is controlled by the arrival and completion of commands from the host system.

#### Active idle

During Active idle, the drive is spinning but is not performing a command. The drive has determined that the previous command sequence (group of associated commands) is complete. Some of the drive electronics have been powered down but the drive can still respond to a new command within 40 milliseconds. The transition from performance idle to Active idle is controlled by IBM's patented Adaptive Battery Life Extender technology.

**Low Power idle**

During Low Power idle, the drive is spinning but is not performing a command. The drive has determined that the previous command sequence (group of associated commands) is complete. Some of the drive electronics have been powered down but the drive can still respond to a new command within about 300 milliseconds. The transition from Performance idle to low power idle is controlled by IBM's patented Adaptive Battery Life Extender technology.

**Standby**

In Standby mode, the drive is not spinning and is not performing a command. All electronics except for the command interface are turned off. The transition to Standby is controlled by a programmable timer which is set by the host system using standard ATA commands. After receiving a new command, the drive will start spinning again and perform the command within 2 to 3 seconds (typically).

**Sleep**

In Sleep mode, the drive is not spinning and is not performing commands. All of the electronics are turned off. The transition to Sleep mode is controlled by a command which is sent by the host system. The transition from Sleep can only be triggered by a reset.

**Electromagnetic compatibility**

The drive meets the following worldwide EMC requirements when installed in a suitable enclosure and exercised with a random accessing routine at the maximum data rate:

United States Federal Communications Commission

(FCC) Rules and Regulations (Class B), Part 15.

This drive is certified for compliance to EC directive 89/336/EEC.

C-Tick Mark complies with Australian EMC standard, AS/NZS 3548 : 1995 Class B.

**Operating environment**

The drive operates within its performance limits when the following environment is maintained. Product life calculations are based on the nominal environment for a typical application.

Relative humidity	
Operating	8% to 90% non-condensing
Non-operating	5% to 95% non-condensing

Wet bulb temperature	
Operating	29.4 °C non-condensing
Non-operating	40 °C non-condensing

Elevation	
Operating	-300 to 3,048 m (10Kft)
Non-operating	-300 to 12,192 m (40Kft)

Temperature	
Operating	5 to 55 °C
Non-operating	-40 to 65 °C
Temperature gradient	20 °C/hour

**Air cooling requirement**

The host system must provide sufficient air flow across the drive to maintain the temperature at less than 60 °C at the center of the top cover of the drive and below 63 °C

at the center of the card of the drive.

**Operating shock**

The drive will withstand, with no hard error, a 125G half-sine wave shock pulse of 2ms duration or 10G for 11ms.

**Non-operating shock**

The drive will withstand, with no permanent damage or degradation in performance, a 120G half-sine wave shock pulse of 11ms duration or 600G for 2ms.

**Operating and non-operating vibration**

Due to the complexity of this subject, we recommend that users contact the distributor to discuss how to perform the necessary measurements if they believe this to be an area which requires evaluation.

**S.M.A.R.T. function**

The intent of Self-Monitoring, Analysis, and Reporting Technology (S.M.A.R.T.) is to protect user data and prevent unscheduled system downtime that may be caused by predictable degradation or fault of the device. By monitoring and storing critical performance and calibration parameters, S.M.A.R.T. devices employ sophisticated data analysis algorithms to predict the likelihood of near-term degradation or fault

condition. By alerting the host system of a negative reliability status condition, the host system can warn the user of the impending risk of a data loss and advise the user of appropriate action. Since S.M.A.R.T. utilizes the internal device microprocessor and other device resources, there may be some small overhead associated with its operation. However, special care has been taken in the design of the S.M.A.R.T. algorithms to minimize the impact to host system performance. Actual impact of S.M.A.R.T. overhead is dependent on the specific device design and the usage patterns of the host system. To further ensure minimal impact to the user, S.M.A.R.T. capable devices are shipped from the device manufacturer's factory with the S.M.A.R.T. feature disabled. S.M.A.R.T. capable devices can be enabled by the system OEMs at the time of system integration or in the field by after market products.

For further details refer to the drive specification.

- Measures should be taken against ESD.
- The breathing hole on top of the drive should not be covered.
- Pressure should not be applied to the top cover of the drive.
- The drive should be operated within the specification of less than 140 power-on hours per month.
- Seeing, Writing, and Reading operation of the drive should be no more than 20% of power-on hours.
- The power requirements of the drive are to be satisfied.
- The drive frame is to be grounded electrically to the system by four screws.
- The drive should be mounted with the recommended screw depth and torque.
- Physical and electrical requirements of the interface are to be satisfied per ATA-4.
- The proper power off sequence should be used (see the drive specification for further details).

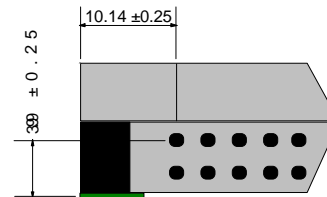
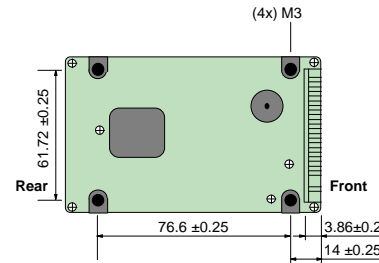
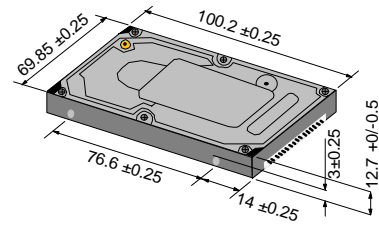

### Mechanical data

#### Weight

137 grams typical, 140 grams maximum.

Dimensions	S.I. Metric
Height	12.7mm +0/- 0.5
Width	69.85mm +/- 0.25
Length	100.2mm +/- 0.25

### Drive usage condition

The drive is designed to be used under the following conditions:

- Levels of Shock, Vibration, Temperature, Humidity, Altitude, and Magnetic Field should be within the specifications.

### Caution

- Do not press on the drive during handling or installation.
- Do not cover the drive's breather hole.

### Mounting orientation

The recommended mounting screw torque is  $3 \pm 0.5$  kgf.cm. The recommended mounting screw thread length is  $3.0 \pm 0.3$  mm for bottom and  $3.5 \pm 0.5$  mm for horizontal mounting.

The drive mounting hole locations and sizes are shown opposite.



© International Business Machines Corporation 2000

[www.ibm.com/harddrive](http://www.ibm.com/harddrive)

**IBM Hard Disk Drive Technical Support Center**

Dept. WCN  
3605 Highway 52 North  
Rochester, MN 55901  
Telephone: 888.IBM.5214 or 507.286.5825  
Fax: 507.253.DRIVE  
E-mail: [drive@us.ibm.com](mailto:drive@us.ibm.com)

**Singapore Technical Support Center**

Telephone: (65)6418.9595 or 1800.418.9595  
E-mail: [drive@sg.ibm.com](mailto:drive@sg.ibm.com)

**IBM Storage Systems Division**

5600 Cottle Road  
San Jose, CA 95193  
[www.ibm.com/storage](http://www.ibm.com/storage)

Printed in the United States of America  
04-2000  
All Rights Reserved

IBM, No-ID, and Predictive Failure Analysis are the registered trademarks of International Business Machines Corporation.

AMP is a trademark of AMP Incorporated.  
DATA MATE is a trademark of AMP Incorporated.  
Molex is a trademark of Molex Incorporated.

Other company, product, and service names may be trademarks or service marks of others.

Produced by the IBM Hard Disk Drive Technical Support Center.

OEM Hard Disk Drive Specifications for  
DCXA-208100/210000, revision 0.2

This product summary is not a substitute for the full production specification, which should be used when detailed information is required.

Product Description data represents IBM's design objectives and is provided for comparative purposes; actual results may vary based on a variety of factors. This product data does not constitute a warranty. Questions regarding IBM's warranty terms or methodology used to derive this data should be referred to the IBM Hard Disk Drive Technical Support Center. Data subject to change without notice.

Date: 04 April 2000