



## Product summary

# Deskstar 40GV

Ultra ATA/100



Models: DTLA-305010  
DTLA-305020  
DTLA-305030  
DTLA-305040

---

### Introduction

IBM's latest Deskstar drives are ideal for high-performance desktop users. These drives offer capacities of up to 41 GB, a rotational speed of 5400 RPM and an average seek time of 9.5 ms. The Deskstar 40GV provides users with access to some of the highest capacities and performance in the industry.

---

### Applications

- High performance Desktop personal computers
- Entry workstations
- Multimedia applications
- Video editing

---

### Features

- 10.2 GB, 20.5 GB, 30.7 GB, and 41.1 GB formatted capacities
- Industry standard interface
  - PIO Mode 4 rates up to 16.6 MB/s
  - Ultra DMA rates up to 100 MB/s
- 31.8 MB/s sustained data transfer rate (typical)
- Rotational speed 5400 RPM
- Average seek time 9.5 ms (read)
- Average latency 5.56 ms
- 512 KB segmented sector buffers
- ECC on-the-fly
- Power saving modes
- S.M.A.R.T. function support
- Drive Fitness Test (DFT) technology
- Transparent Defect Management with Automatic Defect Reallocation (ADR)
- Security function support
- Glass substrate disks

---

### Advantages

- Range of capacities to meet the need for increasing storage requirements
- Popular interface with excellent performance
- Excellent data rate across disk surface
- Fast access to data
- Fast access to data and improved throughput
- High reliability
- Reduced power consumption
- Protection of user data
- No user intervention required; defects are reallocated on the fly
- Password protection for sensitive data
- Improved data integrity
- Longer disk lifetime

**Connectors**

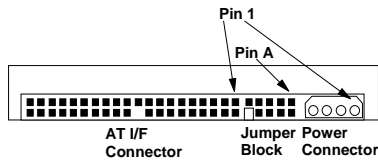

The DC power connector is designed to mate with AMP (part 1-480424-0) using AMP pins (part 350078-4 - strip) or (part 61173-4 loose piece), or their equivalents. Pin assignments are shown below.

*Note:* The AT signal connector is a 40 pin connector.

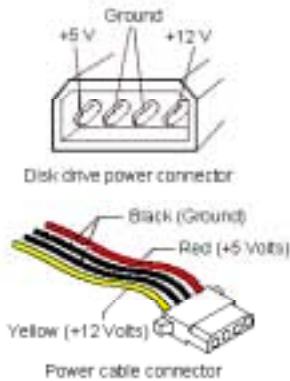

**Cabling**

The maximum cable length from the host system to the drive must not exceed 18 inches.

For systems operating with Ultra DMA mode 3, 4, or 5 the 80-conductor ATA cable assembly must be used.

**Jumper block**

**Jumper settings**

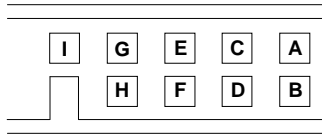

Jumper pins are located between power pins and AT interface pins.

**16 head logical architecture**

Master active*	A-B and G-H
Slave active	A-B and C-D
Cable Select	A-B and E-F
Master/Slave present	E-F and G-H
Reserved	I

**15 head logical architecture**

Master active	A-C and G-H
Slave active	A-C
Cable select	A-C and E-F
Master/Slave present	A-C, E-F, and G-H
Reserved	I

All other jumper setting patterns are reserved.

\* Shipping default

**DC power requirements**

Connection to the drive should be made in low voltage isolated secondary circuits (SELV). The following voltage specification is applied at the power connector of the drive. There is no special power on/off sequencing required.

**Power supply current**

	+5 Volts (amps RMS)	+12 Volts (amps RMS)	Total (watts)
Idle average	0.26	0.30	4.9
Idle ripple (peak to peak)	0.29	0.43	
Seek peak	0.44	1.91	
Seek average <sup>1</sup>	0.27	0.54	7.9
Start up (max.)	0.98	1.86	
RND R/W peak	0.94	1.91	
RND R/W average <sup>2</sup>	0.41	0.54	8.6
Standby average	0.27	0.017	1.6
Sleep average	0.18	0.017	1.1

<sup>1</sup> Random seeks at 40% duty cycle.

<sup>2</sup> Seek duty = 30%, W/R duty = 45%, Idle Duty = 25%.

**Power supply generated ripple**

	Maximum [mV pp]	MHz
+5V DC	250	0-10
+12V DC	250	0-10

**Data organization (logical)**

Number of heads	16
Sectors/track	63
Number of cylinders	16,383

**Customer usable data bytes**

DTLA-	
305010	10,278,051,840
305020	20,576,747,520
305030	30,738,677,760
305040	41,174,136,880

### Hot Plug/Unplug support

Hot plugging/unplugging is not allowed because damage to the drive electronics may result if the power supply cable is connected or disconnected while power is being applied to the drive.

### Environment

#### Operating conditions

Temperature	5 to 55°C
Relative humidity	8 to 90% noncondensing
Maximum wet bulb temperature	29.4°C noncondensing
Maximum temperature gradient	15°C/hour
Altitude	-300 to 3048 m

#### Nonoperating conditions

Temperature:	
- shipping	-40 to 65°C
- storage	0 - 65°C
Relative humidity	5 to 95% noncondensing
Maximum wet bulb temperature	35°C noncondensing
Altitude	-300 to 12,000 m

#### Operating shock

The shock test consists of ten shocks input in each axis and direction for total of 60. There must be a minimum of 30 seconds delay between shock pulses.

The drive withstands the following half-sine shock pulse with no data loss:

- 10 G for a duration of 11 ms
- 30 G for a duration of 4 ms
- 55 G for a duration of 2 ms

#### Nonoperating shock

The drive withstands the following half-sine shock pulse with no data loss:

- 400 G for a duration of 2 ms

#### Rotational shock

No data loss is incurred with the following rotational shocks applied around the axis of the actuator pivot:

- 30,000 rad/s<sup>2</sup> for a duration of 1 ms
- 20,000 rad/s<sup>2</sup> for a duration of 2 ms

#### Acoustics

The upper limit criteria of the A-weighted sound power levels are given in Bel relative to one pico watt and are shown in the following table. The measurement method is in accordance with ISO7779.

##### A-weighted sound power level (Bel)

Mode	typical	max
Idle	3.0	3.4
Operating	3.7	4.0

#### Electromagnetic compatibility

When installed in a suitable enclosure and exercised with a random accessing routine at maximum data rate, the drive meets the following worldwide EMC requirements:

- United States Federal Communications Commission (FCC) Rules and Regulations (Class B), Part 15.
- European Economic Community (EEC) directive number 76/889 related to the control of radio frequency interference and the Verband Deutscher Elektrotechniker (VDE) requirements of Germany (GOP).

#### CE Mark

The drive complies with EC directive 879/336/EEC. CE mark for the certification is indicated on the drive label.

#### C-Tick Mark

The drive complies with the following Australian EMC standard: Limits and methods of measurement of radio disturbance characteristics of information technology equipment, AS/NZS 3548:1995 CLASS-B.



**ATTENTION:** The drive must be protected against electrostatic discharge especially when being handled. The safest way to avoid damage is to put the drive in an anti-static bag before ESD wrist straps are removed.

Drives should only be shipped in approved containers. Severe damage can be caused to the drive if the packaging does not adequately protect against the shock levels induced when a box is dropped. Consult your IBM representative if you do not have an approved shipping container

**Command descriptions**

The following commands are supported by the drive:

Commands	(Hex)	P
Check Power Mode	E5	3
Check Power Mode*	98	3
Execute Device Diagnostic	90	3
Flush Cache	E7	3
Format Track	50	2
Identify Device	EC	1
Idle	E3	3
Idle*	97	3
Idle Immediate	E1	3
Idle Immediate*	95	3
Initialize Device Parameters	91	3
NOP	00	3
Read Buffer	E4	1
Read DMA (retry)	C8	4
Read DMA (no retry)	C9	4
Read DMA Queued	C7	5
Read Long (retry)	22	1
Read long (no retry)	23	1
Read Multiple	C4	1
Read Native Max Address	F8	3
Read Sectors (retry)	20	1
Read Sectors (no retry)	21	1
Read Verify Sectors (retry)	40	3
Read Verify Sectors (no retry)	41	3
Recalibrate	1x	3
Security Disable Password	F6	2
Security Erase Prepare	F3	3
Security Erase Unit	F4	2
Security Freeze Lock	F5	3
Security Set Password	F1	2
Security Unlock	F2	2
Seek	7x	3
Service	A2	5
Set Features	EF	3
Set Max Address	F9	3
Set Multiple Mode	C6	3
Sleep	E6	3
Sleep*	99	3

SMART Disable Operations	B0	3
SMART Enable/Disable Attribute Autosave	B0	3
SMART Enable Operations	B0	3
SMART Execute Off-line Data Collection	B0	3
SMART Read Attribute Values	B0	1
SMART Read Attribute Thresholds	B0	1
SMART Return Status	B0	3
SMART Save Attribute Values	B0	3
SMART Read Log Sector	B0	1
SMART Write Log Sector	B0	2
SMART Enable/Disable Automatic Off-line Data Collection	B0	3
Standby	E2	3
Standby*	96	3
Standby Immediate	E0	3
Standby Immediate*	94	3
Write Buffer	E8	2
Write DMA (retry)	CA	4
Write DMA (no retry)	CB	4
Write DMA Queued	CC	5
Write Long (retry)	32	2
Write Long (no retry)	33	2
Write Multiple	C5	2
Write Sectors (retry)	30	2
Write Sectors (no retry)	31	2

**Protocol**

- 1 : PIO data IN command
- 2 : PIO data OUT command
- 3 : Non data command
- 4 : DMA command
- 5 : DMA queued command
- + : Vendor specific command

Note: Commands marked \* are alternate command codes for previously defined commands

**Signal definition**

Pin	Signal	I/O
01	RESET-	I
02	GND	
03	DD7	I/O
04	DD8	I/O
05	DD6	I/O
06	DD9	I/O
07	DD5	I/O
08	DD10	I/O
09	DD4	I/O
10	DD11	I/O
11	DD3	I/O
12	DD12	I/O
13	DD2	I/O
14	DD13	I/O
15	DD1	I/O
16	DD14	I/O
17	DD0	I/O
18	DD15	I/O
19	GND	
(20)	Key	
21	DMARQ	O
22	GND	
23	DLOW-(*)	I
24	GND	
25	DIOR-(*)	I
26	GND	
27	IORDY(*)	O
28	CSEL	I
29	DMACK-	I
30	GND	
31	INTRQ	O
32	IOCS16-(**)	O
33	DA1	I
34	PDIAG-	I/O
35	DA0	I
36	DA2	I
37	CS0-	I
38	CS1-	I
39	DASP-	I/O
40	GND	

**Notes:**

(\*\*) at ATA-2

“O” designates an output from the drive.

“I” designates an input to the drive.

“I/O” designates an input/output common.

(\*) The signal lines marked with (\*) are redefined during the Ultra DMA protocol to provide special functions. If the Ultra DMA transfer mode was previously chosen via SetFeatures, these lines change

DMA burst. The drive becomes aware of this change upon assertion of the DMACK- line. These lines revert back to their original definitions upon the deassertion of DMACK- at the termination of the DMA burst. See the following table.

**Ultra DMA definitions**

	Special definition (for Ultra DMA)	Conventional definition
Write operation	DDMARDY-	IORDY
	HSTROBE	DIOR-
	STOP	DIOW-
Read operation	HDMARDY-	DIOR-
	DSTROBE	IORDY
	STOP	DIOW-

**Mechanical data**

Height	25.4±0.4 mm
Width	101.6±0.4 mm
Length	146.0±0.8 mm
Weight (max)	550 grams

**Mounting**

The drive will operate in all axes (six directions). Performance and error rate will stay within specification limits if the drive is operated in the other permissible orientations from which it was formatted.

For reliable operation the drive must be mounted in the system securely enough to prevent damage from excessive motion or vibration during seek operation or spindle rotation, using appropriate screws or equivalent mounting hardware.

Drive level vibration test and shock test are to be conducted with the drive mounted to the table using the bottom four screws.

**Mounting holes**

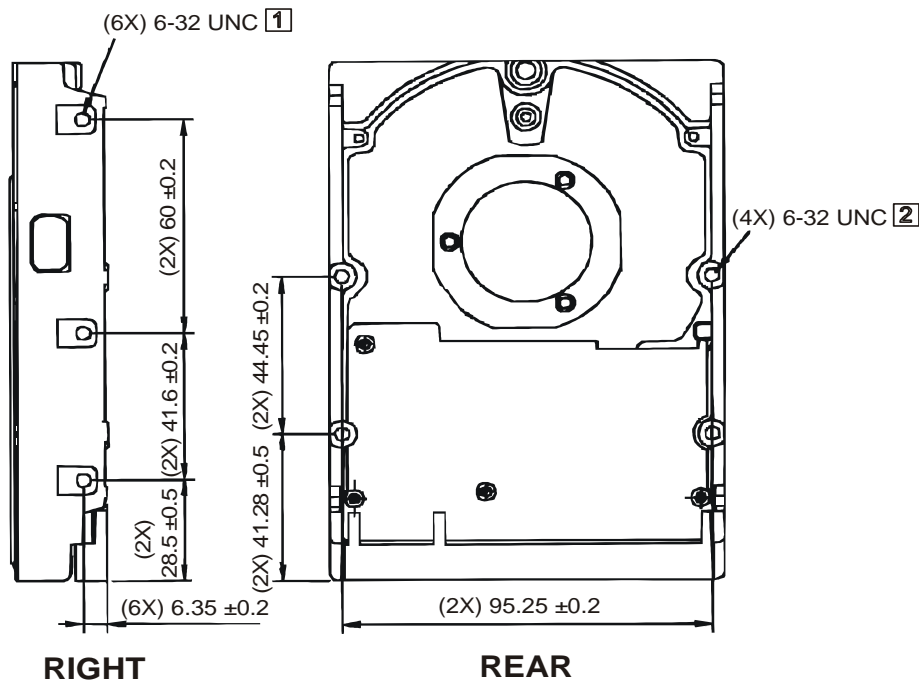

Recommended torque 0.6 - 1.0 Nm

- 1 Max allowable penetration of noted screw to be 4.5 mm.
- 2 Max allowable penetration of noted screw to be 4.0 mm.

Mechanical dimensions

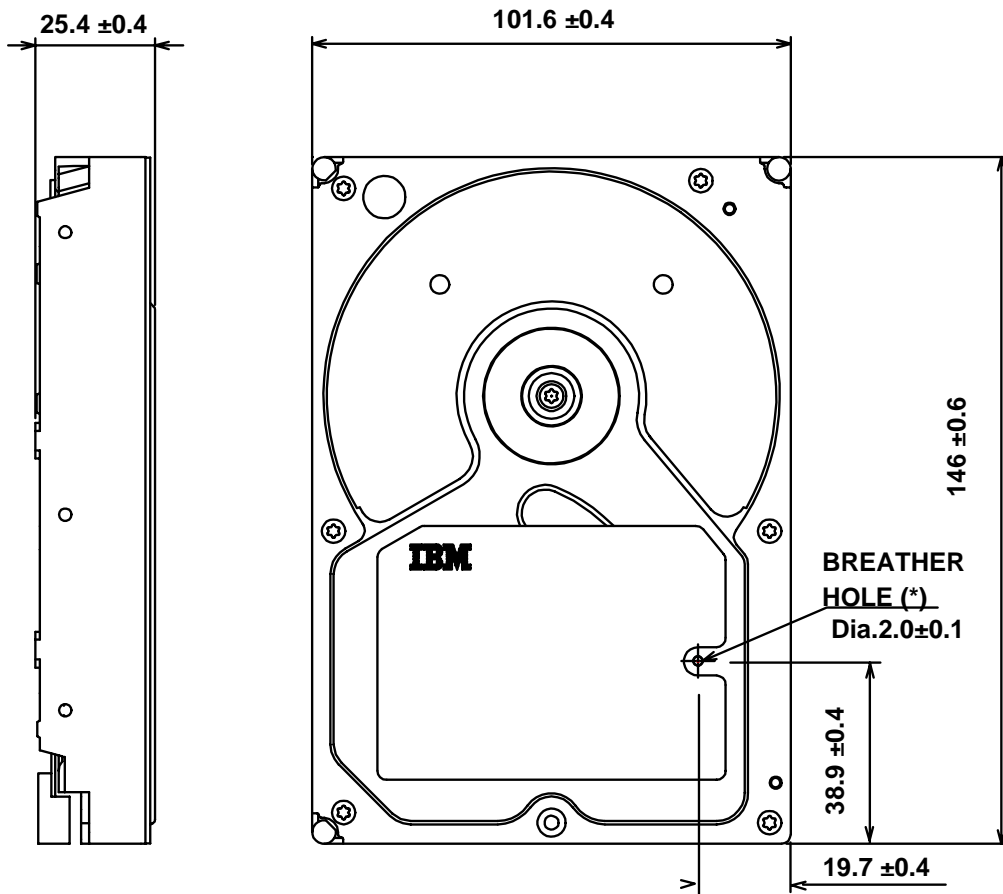

LEFT

FRONT

\* DO NOT BLOCK THE BREATHER HOLE .



© International Business Machines Corporation 2001

[www.ibm.com/harddrive](http://www.ibm.com/harddrive)

**IBM Technology Group Support Center**  
Telephone: 888.426.5214 or 507.286.5825  
E-mail: [drive@us.ibm.com](mailto:drive@us.ibm.com)

**Singapore Technology Group Support Center**  
Telephone: (65)6418.9595 or 1800.418.9595  
E-mail: [drive@sg.ibm.com](mailto:drive@sg.ibm.com)

**UK Technology Group Support Center**  
Telephone: 44.1475.898.125  
E-mail: [drive@uk.ibm.com](mailto:drive@uk.ibm.com)

**Germany Technology Group Support Center**  
Telephone: 49.7032.153050  
E-mail: [drive@de.ibm.com](mailto:drive@de.ibm.com)

**IBM Systems Storage Division**  
5600 Cottle Road  
San Jose CA 95193  
[www.ibm.com/storage](http://www.ibm.com/storage)

Printed in the United States of America  
08-2001  
All Rights Reserved

IBM, Drive-TIP, No-ID, and Predictive Failure Analysis are the registered trademarks of International Business Machines Corporation.

AMP is a trademark of AMP Incorporated.  
DATA MATE is a trademark of AMP Incorporated.  
Molex is a trademark of Molex Incorporated.

Other company, product, and service names may be trademarks or service marks of others.

Produced by the IBM Technology Group Support Center.

Deskstar 40GV & 75GXP Hard Disk Drive Specifications, revision 2.0

This product summary is not a substitute for the full production specification, which should be used when detailed information is required.

Product Description data represents IBM's design objectives and is provided for comparative purposes; actual results may vary based on a variety of factors. This product data does not constitute a warranty. Questions regarding IBM's warranty terms or methodology used to derive this data should be referred to the IBM Technology Group Support Center. Data subject to change without notice.

Date: 13 August 2001