



OEM FUNCTIONAL SPECIFICATIONS

for

DHAA-2270 / DHAA-2405 / DHAA-2540

2.5-Inch Hard Disk Drive with ATA Interface



OEM FUNCTIONAL SPECIFICATIONS

for

DHAA-2270 / DHAA-2405 / DHAA-2540

2.5-Inch Hard Disk Drive with ATA Interface

1st Edition, S66G-8101-00 (February 23, 1994)

2nd Edition, S66G-8101-01 (March 02, 1994)

3rd Edition, S66G-8101-02 (April 26, 1994)

The following paragraph does not apply to the United Kingdom or any country where such provisions are inconsistent with local law: INTERNATIONAL BUSINESS MACHINES CORPORATION PROVIDES THIS PUBLICATION “AS IS” WITHOUT WARRANTY OF ANY KIND, EITHER EXPRESS OR IMPLIED, INCLUDING, BUT NOT LIMITED TO, THE IMPLIED WARRANTIES OF MERCHANTABILITY OR FITNESS FOR A PARTICULAR PURPOSE. Some states do not allow disclaimer or express or implied warranties in certain transactions, therefore, this statement may not apply to You.

This publication could include technical inaccuracies or typographical errors. Changes are periodically made to the information herein; these changes will be incorporated in new editions of the publication. IBM may make improvements and/or changes in the product(s) and/or the program(s) described in this publication at any time.

It is possible that this publication may contain reference to, or information about, IBM products (machines and programs), programming, or services that are not announced in your country. Such references or information must not be construed to mean that IBM intends to announce such IBM products, programming, or services in your country.

Technical information about this product is available from your local IBM representative or at **<http://www.ibm.com/harddrive>**

IBM may have patents or pending patent applications covering subject matter in this document. The furnishing of this document does not give you any license to these patents. You can send license inquiries, in writing, to the IBM Director of Commercial Relations, IBM Corporation, Armonk, NY 10577.

© Copyright International Business Machines Corporation 1994. All rights reserved.

Note to U.S. Government Users —Documentation related to restricted rights —Use, duplication or disclosure is subject to restrictions set forth in GSA ADP Schedule Contract with IBM Corp.

Contents

A. Preface	A-1
A.1 Notices	A-1
A.2 Related Documents	A-1
A.3 Glossary	A-1
1. Product Outline	1-1
2. Drive Characteristics	2-1
2.1 Logical Drive Format	2-1
2.2 Data Sheet	2-1
2.3 Performance Characteristics	2-2
2.3.1 Drive Ready Time	2-2
2.3.2 Command Overhead	2-3
2.3.3 Average Seek Time (Including Settling)	2-4
2.3.4 Single Track Seek Time	2-4
2.3.5 Full Stroke Seek	2-4
2.3.6 Average Latency	2-5
3. Data integrity	3-1
3.1 Equipment Status	3-1
3.2 WRITE Safety	3-1
3.3 Data Buffer Test	3-1
3.4 Error Recovery	3-2
4. Physical Format	4-1
4.1 After Formatting	4-1
5. Specification	5-1
5.1 Environment	5-1
5.1.1 Temperature and Humidity	5-1
5.2 DC Power Requirements	5-2
5.3 Error Rate	5-3
5.4 Contact Start Stop (CSS)	5-3
5.5 Mean Time To Failures (MTTF)	5-3
5.6 Warranty	5-3
5.7 Useful Life	5-3
5.8 Preventive Maintenance	5-3
5.9 Mechanical Specifications	5-4
5.9.1 Outline	5-4
5.9.2 Mechanical Dimensions	5-5
5.9.3 Hole Locations	5-5
5.9.4 Connector and Jumper	5-5
5.9.5 Mounting Orientation	5-6
5.9.6 Landing Zone and Lock	5-7
5.10 Vibration and Shock	5-8
5.10.1 Operating Vibration	5-8
5.10.2 Non-Operating Vibrations	5-8
5.10.3 Operating Shock	5-9
5.10.4 Non-Operating Shock	5-9
5.11 Acoustics	5-10
5.11.1 Sound Power Levels	5-10

5.11.2 Sound Power Acceptance Criteria	5-10
5.12 Identification Labels	5-11
5.13 Electromagnetic Compatibility	5-11
5.14 Safety	5-12
5.14.1 Underwriters Lab (UL) Approval	5-12
5.14.2 Canadian Standards Authority (CSA) Approval	5-12
5.14.3 IEC Compliance	5-12
5.14.4 German Safety Mark	5-12
5.14.5 Flammability	5-12
5.14.6 Safe Handling	5-12
5.14.7 Environment	5-12
5.14.8 Secondary Circuit Protection	5-13
5.15 Drive Handling	5-13
6. Electrical Interface Specifications	6-1
6.1 Cabling	6-1
6.2 Interface Connector	6-1
6.3 Signal Definition	6-2
6.4 Interface Logic Signal Levels	6-5
6.5 Reset timings	6-5
6.6 PIO Timings	6-6
6.6.1 DMA timings (Single Word)	6-8
6.6.2 DMA timings (Multiword)	6-9
6.7 Addressing of HDD Registers	6-10

Tables

2-1.	Drive Parameter	2-1
2-2.	Data Sheet	2-1
2-3.	Performance Parameter	2-2
2-4.	Drive Ready Time	2-2
2-5.	Operating Modes	2-3
2-6.	Mode Transition Time	2-3
2-7.	Mechanical Positioning Performance	2-4
2-8.	Single Track Seek Time	2-4
2-9.	Full Stroke Seek Time	2-4
2-10.	Latency Time	2-5
5-1.	DC Power Requirement	5-2
5-2.	Physical Dimension	5-5
5-3.	Random Vibration PSD Profile Breakpoints (Operating)	5-8
5-4.	Random Vibration PSD Profile Breakpoints (Non-Operating)	5-8
5-5.	A-weighted Sound Power Levels	5-10

Figures

5-1.	Outline of DHAA-2xxx	5-4
5-2.	Drive Address Setting by Jumper Cable	5-6
6-1.	44 pin AT Connector	6-1
6-2.	Table of signals	6-2
6-3.	Interface Logic Signal Levels	6-5
6-4.	System Reset timing	6-5
6-5.	PIO cycle timings	6-6
6-6.	Interface Timing Limits	6-7
6-7.	DMA (Single Word) cycle timings	6-8
6-8.	DMA (Multiword) cycle timings	6-9
6-9.	Task File	6-10

A. Preface

A.1 Notices

This document describes the characteristics of the following IBM 2.5-inch, AT interface hard disk drives:

- DHAA-2270 (270MB)
- DHAA-2405 (344MB, 405MB)
- DHAA-2540 (528MB, 540MB)

This document defines the hardware functional specifications. For details about the interface specifications, refer to *OEM Interface Specifications for DHAA-2270/DHAA-2405/DHAA-2540 2.5-Inch Hard Disk Drive with ATA Interface*.

A.2 Related Documents

- Interface Specifications
 - *OEM Interface Specifications for DHAA-2270/DHAA-2405/DHAA-2540 2.5-Inch Hard Disk Drive with ATA Interface*. (Document number: S66G-8102)

A.3 Glossary

<i>Word</i>	<i>Meaning</i>
KBPI	1,000 Bit Per Inch
Mbps	1,000,000 Bit per second
MB	1,000,000 bytes
KB	1,000 bytes
Mb/sq.in	1,000,000 bits per square inch
MLC	Machine Level Control
TBD	To be defined

Note:

IBM and AT

are trademarks or registered trademarks of International Business Machines Corporation.

1. Product Outline

- 2.5-inch form factor
- Formatted data capacity 270/344/405/528/540MB
- 512 bytes/sector
- No-ID physical format
- ATA-2 interface
- CHS and LBA mode
- Interface data transfer capability 8.3MB/sec max
- PIO Data Transfer - Mode 3
- DMA Data Transfer
 - Single Word mode - mode 2
 - Multiword mode - mode 1
- Interleave factor 1:1
- 32 KB Write Cache / 32KB Read Buffer
- Enhanced ECC implementation
 - 128 bit Reed Solomon Code operating 10-bit symbol
 - Multi burst On-The-Fly correction (up to 4 symbols in one sector)
- Automatic retry on errors
- Self Diagnostics during Power On
- Power saving modes
- MR (Magneto Resistive) Head technology
- MCC standardized mounting holes and interface connector
- 1.2watt Idle
- 17mm Height
- MTTF 300,000 power on hours
- 1,7 Run Length Limited (RLL) code
- Multi zone recording (8)
- Media data transfer 36 Mb/sec max
- Average seek time 14ms for read
- Closed Loop actuator servo (Embedded Sector Servo)
- Dedicated head landing zone
- Automatic actuator lock
- All axis (6 directions) mounting
- No preventive maintenance

2. Drive Characteristics

This chapter provides the characteristics of the drives.

2.1 Logical Drive Format

The customer usable data capacity is as shown below.

Descriptions	270MB	344MB	405MB	528MB	540MB
Logical Head Number	16	15	16	16	16
Logical Sectors/Track	63	49	63	63	63
Logical Cylinder Number	524	915	785	1024	1047
Logical Sector Size	512	512	512	512	512
Total Customer Usable Data Sectors	528,192	672,525	791,280	1,032,192	1,055,376
Total Customer Usable Data Bytes	270 MB	344 MB	405 MB	528 MB	540 MB

2.2 Data Sheet

Rotational speed [RPM]	3800
Recording density [KBPI]	83(Ave) / 93.1(Max)
Track density [TPI]	5300
Areal density [Mb/sq.in.]	440(Ave) / 493(Max)
Number of zone	8
Number of disks	
DHAA-2270	1
DHAA-2405	2
DHAA-2540	2
Servo design method	Embedded sector servo

2.3 Performance Characteristics

The drive performance is characterized by the following parameters:

- Command Overhead
- Mechanical Positioning
 - Seek Time
 - Latency
- Data Transfer Speed
- Buffering Operation

Note: The following specification defines the drive characteristics, not the system throughput which is dependant on the system and the application.

Function	Typical
Power on to ready (Typical)	2.7 [sec]
Command overhead	1 [msec]
Seek time: Read	14 [msec]
Seek time: Write	15 [msec]
Rotational speed	3800 [rpm]
Media transfer rate [Mb/sec]	24.9 - 36.0
Interface transfer rate [MB/sec]	8.3 max
Data buffer size [KB]	32(read) / 32(write)

The table shows typical values only. The details are as follows.

2.3.1 Drive Ready Time

Condition (Model)	Typical	Max.
Power On to Ready [sec]	2.7	7.5

Ready The condition in which the drive is able to perform a media access command (read, write) immediately.

Power On This includes the time required for the internal self diagnostics.

2.3.1.1 Operating Modes

Table 2-5. Operating Modes	
Operating Mode	Description
Spin-Up	Start up time period from spindle stop or power down.
Seek	Seek operation mode
Write	Write operation mode
Read	Read operation mode
Idle	Spindle motor and servo system are working normally. Other modules except the servo control and the host interface are sleeping. Commands can be received and processed immediately.
Standby	Spindle motor is stopped. All modules except the host interface are sleeping. Commands can be received immediately. Drive is in an interrupt waiting mode with the lowest power dissipation.

Notes:

1. After power down or spindle stopped, a head locking mechanism secures the heads in the landing zone.
2. Sleep command is considered as standby command. Recovering from standby mode does not need soft reset nor hard reset.

2.3.1.2 Mode Transition Time

Table 2-6. Mode Transition Time			
From	To	Typical [sec]	Max [sec]
Standby	Idle	2.7	6.2
Idle	Standby	2.2	5.0

2.3.2 Command Overhead

Command overhead is defined as the time required:

- from the command is written into command register by a host
- to seek start

2.3.3 Average Seek Time (Including Settling)

Table 2-7. Mechanical Positioning Performance		
Command Type	Typical	Max
Read	14 [msec]	16 [msec]
Write	15 [msec]	17 [msec]

The seek time is measured from the start of actuator's motion to the start of a **reliable read or write operation**. Reliable read or write implies that error correction/recovery is not employed to correct for arrival problems. The average seek time is measured as the weighted average of all possible seek combinations.

$$\text{Weighted Average} = \frac{\sum_{n=1}^{\max} (\max + 1 - n) (T_{n.in} + T_{n.out})}{(\max + 1) (\max)}$$

Where:

max = Maximum seek length

n = Seek length (1 to max)

T_{n.in} = Inward measured seek time for an n track seek

T_{n.out} = Outward measured seek time for an n track seek

2.3.4 Single Track Seek Time

Table 2-8. Single Track Seek Time		
Function	Typical	Max.
Read [msec]	4	5.5
Write [msec]	4	6.5

The single track seek time is the average of the 1000 single track seeks.

2.3.5 Full Stroke Seek

Table 2-9. Full Stroke Seek Time		
Function	Typical	Max.
Read [msec]	23	30
Write [msec]	24	31

Full stroke seek is measured as the average of 1000 full stroke seeks.

2.3.6 Average Latency

Table 2-10. Latency Time		
Rotation	Time for a revolution	Average Latency
3800 [RPM]	15.8 [msec]	7.9 [msec]

3. Data integrity

The drive retains recorded information under all non-write operations.

No more than one sector is lost by hard reset or power down during write operation while write cache is disabled.

In case of that hard reset or power down occurs before completion of data transfer from write cache to disk while write cache is enabled, the data remaining in write cache is lost.

There are three ways to check if the data in the write cache have been written onto the disk. Checking just before power off and hard reset is recommended to prevent data loss.

- To confirm negation of -DASP signal.
- To confirm successful completion of Software Reset.
- To confirm successful completion of the following commands.
Check Power Mode, Execute Drive Diagnostics, Format Track, Identify Drive, Idle, Idle Immediate, Initialize Drive Parameters, Read Buffer, Read Long with Retry, Read Long without Retry, Recalibrate, Seek, Set Features, Set Multiple, Sleep, Standby, Standby Immediate, Write Buffer, Write Long with retry, Write Long without Retry.

3.1 Equipment Status

Equipment status is available to the host system any time the drive is not ready to read, write, or seek. This status normally exists at power-on time and will be maintained until the following conditions are satisfied.

- Access recalibration/tuning is complete.
- Spindle speed meets requirements for reliable operation.
- Self-check of drive is complete.

Appropriate error status is made available to the host system if any of the following condition occur after the drive has once become ready:

- Spindle speed goes outside of requirements for reliable operation.
- “Write fault” is detected.

3.2 WRITE Safety

The verification of write operation involves a read-back check of the CRC or ECC in conjunction with **write fault** detection circuits. The **write fault** detection circuits reveal conditions where write operation was intended and did not occur properly and the CRC or ECC verification occurred for old information, or cases where data is erroneously erased.

3.3 Data Buffer Test

The data buffers, a read buffer and a write buffer used as temporally data storages for read/write data transfer, are tested at a power-on-reset and when a drive self-test is requested by the host. The tests consist of write/read hex ‘00’ and hex ‘FF’ pattern for all bit position of the buffers.

3.4 Error Recovery

Errors occurring with the drive are handled by the error recovery procedure.

Errors that are uncorrectable after application of the error recovery procedures are reported to the host system as non-recoverable errors.

4. Physical Format

On manufacturing process, all sectors of hard disk drive are tested for the magnetical performance, so that only acceptable sectors are used.

In data area, accepted sectors are numbered sequentially for user data sectors.

This mapping information is maintained at firmware level, and data block addressed by logical cylinder, head and sector is translated into physical location on disk(s) automatically. This operation is invisible from application level.

The hard disk drive **never perform low level format** after manufacturing process.

4.1 After Formatting

- Data areas are optimally used after the drive is formatted in factory.

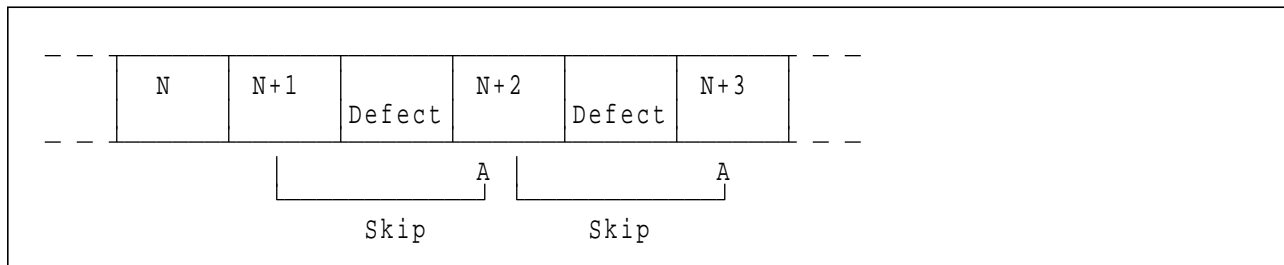

Defects are skipped without any constraint, such as track or cylinder boundary.

5. Specification

This chapter provides the specifications of the drives.

5.1 Environment

The following table shows the environmental conditions.

5.1.1 Temperature and Humidity

Operating Conditions	
Temperature	5 to 55[°C] (See note)
Relative Humidity	8 to 90 [% RH] non-condensing
Maximum Wet Bulb Temperature	29.4[°C] non-condensing
Maximum Temperature Gradient	20[°C]
Altitude	- 300 to 3000 [m]
Non-Operating Conditions	
Temperature	- 40 to 65[°C]
Relative Humidity	5 to 95 [% RH] non-condensing
Maximum Wet Bulb Temperature	40[°C] non-condensing
Maximum Temperature Gradient	20[°C / Hour]
Altitude	- 300 to 12,000 [m]
Note: The system has to provide sufficient ventilation to maintain a surface temperature below [60°C] at the center of the top cover of the drive.	

5.2 DC Power Requirements

Table 5-1. DC Power Requirement		
Power	Requirement	Note
Nominal supply	+ 5 [V]	
Power supply ripple (0– 20[MHz])	100 [mV p-p max]	1
Tolerance	± 5 %	2
Mode:	Supply Current (Populated Mean) [A RMS]	
Idle (average)	0.24	
Read / write (average)	0.56	
Seek (average)	0.40	
Standby	0.08	
Start up (peak)	0.94	
Start up (average to ready)	0.70	
Supply rise time	7– 100 ms	

Notes:

1. The maximum ripple is measured at input to the drive.
2. The drive does not incur damage by an over-voltage condition of +25% and the maximum duration is less than 20 [msec].

5.3 Error Rate

- Probability of not recovering data 1 in 10^{13} bits read
- ECC implementation
 - 128-bit Non-interleave Reed Solomon Code operating 10-bit symbol is used to cover the data fields.
 - On-The-Fly correction covers up to four symbols of error in one sector.
 - Off-line correction covers up to five symbols of error in one sector.

5.4 Contact Start Stop (CSS)

The drive meets the specified error rates after the following start/stop or power on/off cycles in the environment.

- 52,000 cycles under the temperature of 40°C and 15– 20% humidity.
- 10,400 cycles under the temperature of 55°C and 8– 15% humidity.

5.5 Mean Time To Failures (MTTF)

300,000 power-on hours (POH).

Usage assumption for the MTTF is as follows.

The drive usage is assumed as 720 POH (power on hour) per month (43,200 POH for 5 years), with 50 on/off cycles per month and a drive access (seek, read, write) rate of 20% of power on time. The drive meets the failure rate described in the reliability section.

The drive usage is assumed as 110 POH (power on hour) per month (6,600 POH for 5 years), with 1,000 on/off cycles per month and a drive access (seek, read, write) rate of 20% of power on time. The drive meets the failure rate described in the reliability section.

Note: In both cases, the usage is based on the following conditions.

- The drive enters into Standby mode, Sleep mode or Power off at least once a day.
- The environment temperature is less than 40°C.

5.6 Warranty

The warranty will be covered by contracts.

5.7 Useful Life

The useful life of the drive is 5 years minimum.

5.8 Preventive Maintenance

Not required.

5.9 Mechanical Specifications

5.9.1 Outline

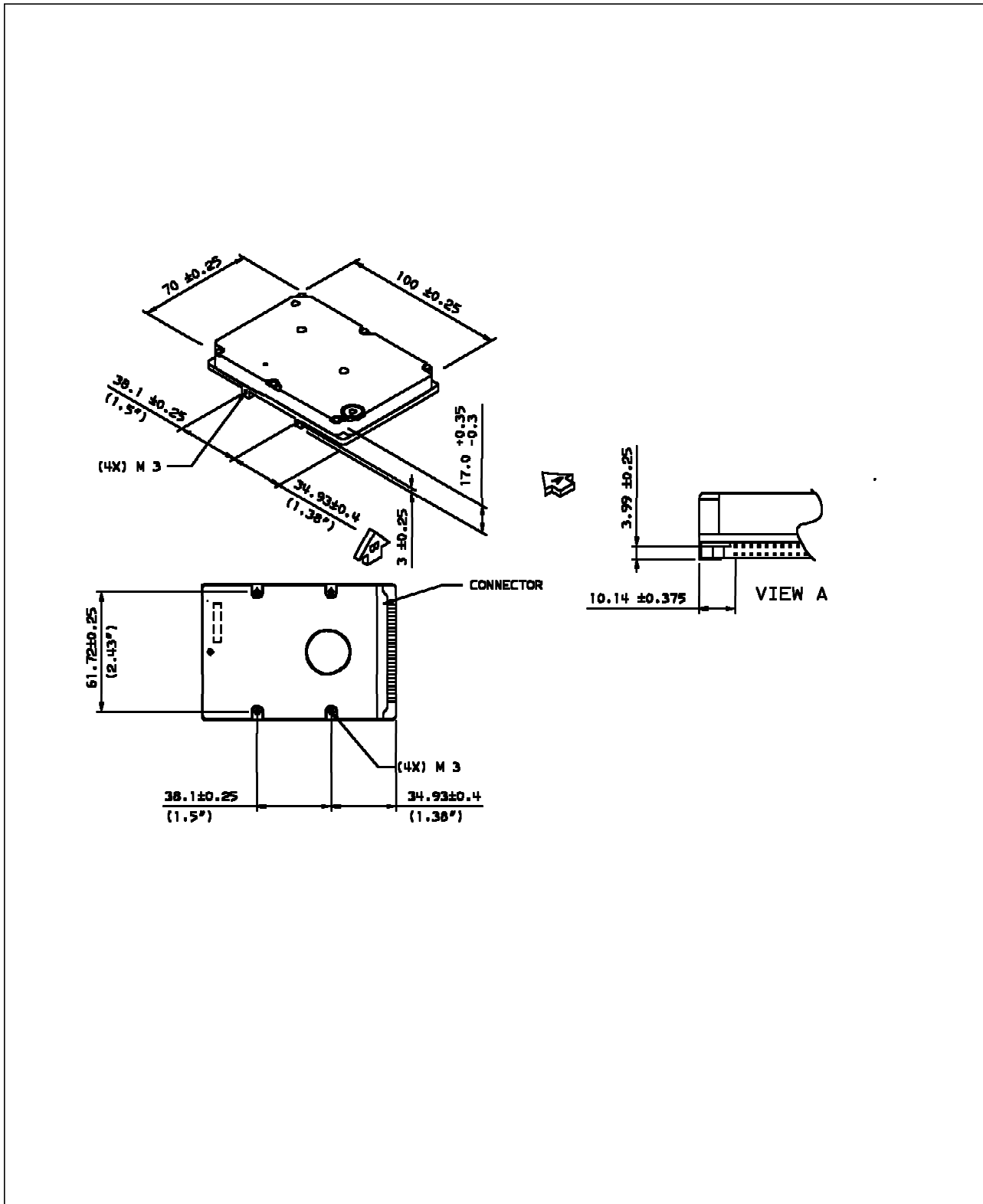

Figure 5-1. Outline of DHAA-2xxx

5.9.2 Mechanical Dimensions

Table 5-2. Physical Dimension	
Height [mm]	17.0 + 0.35 – 0.3
Width [mm]	70.0 ± 0.25
Length [mm]	100.0 ± 0.25
Weight [gram]	180 Max.

5.9.3 Hole Locations

Figure 5-1 on page 5-4 shows the outline of the drive which includes the hole locations. Size and location of the mounting holes comply with MCC.

5.9.4 Connector and Jumper

The AT signal connector is designed to mate with Dupont part number 69764-044 or equivalent. Size and location of the mounting holes comply with MCC.

A jumper is used for the drive to designate the drive address, master or slave.

5.9.4.1 Drive Address Setting

A jumper cable is available at the interface connector to designate the drive address, master or slave. The set position of the jumper cable is as shown in Figure 5-2 on page 5-6.

Using Cable Selection, the drive address depends on the condition of pin 28 of the AT interface cable. In the case when pin 28 is ground or low, the drive is a Master. If pin 28 is open or high level, the drive is a Slave.

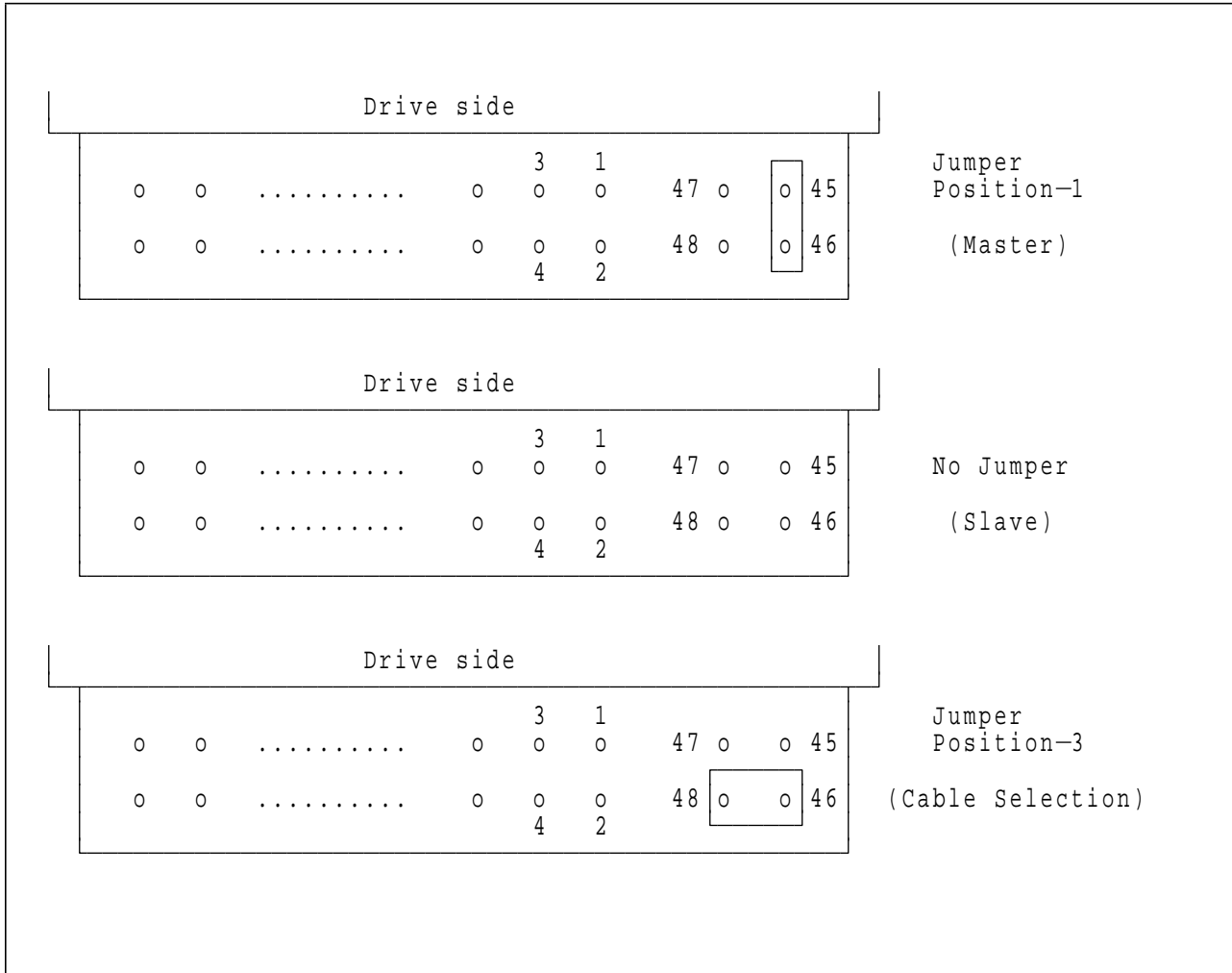

Figure 5-2. Drive Address Setting by Jumper Cable

5.9.4.2 Default Setting

The default setting of jumper cable at shipment is Position-1 (Master).

5.9.5 Mounting Orientation

The drive operates in all axes (6 directions). The drive operates within the specified error rates when tilted ± 5 degrees from these positions.

Performance and error rate stay within specification limits even if the drive is operated in other orientations from which it was formatted. Thus a drive formatted in the horizontal orientation operates in the vertical position without any degradation, and vice versa.

The recommended mounting screw torque is 3 ± 0.5 [Kgf.cm].

The recommended mounting screw depth is 3.5 ± 0.5 [mm] for bottom and 5.0 ± 0.5 [mm] for horizontal mounting.

The system is responsible for mounting the drive securely enough to prevent excessive motion or vibration of the drive at seek operation or spindle rotation, using appropriate screws or equivalent mounting hardware.

The vibration test and the shock test are to be conducted with the drive mounted to the table using four bottom screws.

5.9.6 Landing Zone and Lock

A landing zone on the disk, not the data area of the disk, is provided to protect the disk data during shipping, movement, or storage. After power down, a head locking mechanism secures the heads in this zone.

5.10 Vibration and Shock

All vibration and shock measurements in this section are made with the drive that has no mounting attachments for the systems. The input power for the measurements is applied to the normal drive mounting points.

5.10.1 Operating Vibration

The drive operates with no non-recoverable errors while being subjected to the following vibration levels.

The measurements are carried out during 30 minutes of random vibration using the power spectral density (PSD) levels specified in IBM standards as V5L. The vibration test level for V5L is 0.67G (RMS).

Hz	Random Vibration PSD Profile Breakpoints (Operating)								
[Hz]	5	17	45	48	62	65	150	200	500
$\times 10^{-3}$ [G ² /Hz]	0.02	1.1	1.1	8.0	8.0	1.0	1.0	0.5	0.5

Note: The specified levels are measured at the mounting points.

5.10.2 Non-Operating Vibrations

The drive does not sustain permanent damage or loss of recorded data after being subjected to the environment described below.

5.10.2.1 Random Vibration

The test consists of a random vibration applied in each of three mutually perpendicular axes with the time duration of 15 minutes per axis. The PSD levels for the test simulates the shipping and relocation environment which is shown below.

Hz	Random Vibration PSD Profile Breakpoints (Non-Operating)						
Hz	2	4	8	40	55	70	200
[G ² /Hz]	0.001	0.03	0.03	0.003	0.01	0.01	0.001

Overall RMS (Root Mean Square) level of vibration is 1.04G (RMS).

5.10.2.2 Swept Sine Vibration

- 2 G (Zero to peak), 5 to 200 to 5 Hz sine wave
- 0.5 oct/min sweep rate
- 15 minutes dwell at two major resonances

5.10.3 Operating Shock

The drive meets the following criteria.

- No data loss or permanent damages within shock pulses of 20G, 2ms half-sine wave.
- No data loss or permanent damages at Idle, Seek and Read modes within shock pulses of 60G 3.5ms half-sine wave.

The shock pulses of each level are applied to the drive, 10 pulses in each axis and direction for total 60. There must be a minimum of a 3 seconds delay between each shock pulse. The input level is applied to the base plate where the drive is attached with four screws.

5.10.4 Non-Operating Shock

The drive withstands without damage or degradation of performance, a 120G half-sine wave shock pulse of 11 ms duration and a 250G half-sine wave shock pulse of 2ms duration on six sides when heads are parked. (When the power is not applied to the unit, the heads are automatically located on the parked position.)

All shocks are applied in each direction of the drive three mutually perpendicular axes, one axis at a time. Input levels are measured at the frame of the hard disk drive.

5.11 Acoustics

The following shows the acoustic levels.

5.11.1 Sound Power Levels

The upper limit criteria of the A-weighted sound power levels are given in bels relative to one pico watt and are shown in the following table.

Table 5-5. A-weighted Sound Power Levels	
Mode	A-weighted Sound Power Level [Bel]
Idle	4.5
Operating	4.8

Background power levels of the acoustic test chamber for each octave band are to be recorded.

Sound power levels are measured with the drive supported by spacers so that the lower surface of the drive is located 25 ± 3 mm height from the chamber floor. No sound absorbing material shall be used.

The acoustical characteristics of the drive subsystem are measured under the following conditions.

Idle mode:

Powered on, disks spinning, track following, unit ready to receive and respond to control line commands.

Operating mode:

Continuous random cylinder selection and seek operation of actuator with a dwell time at each cylinder. Seek rate for the drive can be calculated as shown below.

Dwell time = $(0.5 + N) \times 60/\text{RPM}$

Seek rate = $1/(\text{Average seek time} + \text{Dwell time})$

Where N = number of maximum data surfaces (N=4 for DHAA-2540)

5.11.2 Sound Power Acceptance Criteria

Statistical upper limit $(L_{\text{Woct}})_{\text{stat}}$ is calculated with the following formula.

$$(L_{\text{Woct}})_{\text{stat}} = (L_{\text{Woct}})_{\text{m}} + k \times (s_{\text{t}})_{\text{Woct}}$$

where:

$(L_{\text{Woct}})_{\text{m}}$ is the mean value of the sound power level for samples of N drives.

$(s_{\text{t}})_{\text{Woct}}$ is the total standard deviation for sound power level at each octave band.

$$(s_{\text{t}})_{\text{Woct}} = \text{SQRT}((s_{\text{R}})_{\text{W}}^2 + (s_{\text{P}})_{\text{Woct}}^2)$$

$(s_{\text{R}})_{\text{W}}$ is the standard deviation of reproducibility for sound power level.

Assume $(s_{\text{R}})_{\text{W}} = 0.075$ B.

$(s_{\text{P}})_{\text{Woct}}$ is the standard deviation of the samples for sound power level at each octave band.

k is a coefficient determined by number of samples (N) as shown below.

N	3	4	5	6	7	8	9	10	11	12	13	14	15
k	3.19	2.74	2.74	2.49	2.33	2.22	2.13	2.07	2.01	1.97	1.93	1.90	1.87

The calculated left hand side of the criterion equation above is referred to as LWU and rounded to the nearest 0.05 bel. The individual terms may be rounded to the nearest 0.01 bel before calculation.

5.12 Identification Labels

The following labels are affixed to every drive.

1. A label placed on the top of the HDA contains the statement “Made by IBM” or equivalent, Part number, and MLC number.
2. A bar code label placed on the disk drive is based on user request. The location is to be designated in the drawing.
3. Labels containing the vendor's name, disk drive model number, serial number, place of manufacture and UL/CSA logos.

Except for the bar code, the labels may be integrated.

5.13 Electromagnetic Compatibility

The drive, when installed in the host system and exercised with a random accessing routine at maximum data rate, meets the worldwide EMC requirements listed below.

IBM will provide technical support to meet the requirements to comply with the EMC specifications.

- United States Federal Communications Commission (FCC) Rules and Regulations (Class B), Part 15. IBM Corporate Standard C-S 2-0001-026 (A 6 dB buffer should be maintained on the emission requirements).
- European Economic Community (EEC) directive number 76/889 related to the control of radio frequency interference and the Verband Deutscher Elektrotechniker (VDE) requirements of Germany (GOP). IBM National Bulletin NB 2-0001-400, NB 2-0001-401, and NB 2-0001-403.
- Electrostatic Discharge Susceptibility limits for a Class 2 ESD environment specified in IBM Corporate Standard C-S 2-0001-005.
- Radiated Electromagnetic Susceptibility (RES) as specified in IBM Corporate Standard C-S 2-0001-012.

5.14 Safety

The following shows the safety standards for the different countries.

5.14.1 Underwriters Lab (UL) Approval

All models, DHAA-2270, DHAA-2405, and DHAA-2540 comply with UL 1950.

5.14.2 Canadian Standards Authority (CSA) Approval

All models, DHAA-2270, DHAA-2405 and DHAA-2540 comply with CSA C22.2 #950-M89.

5.14.3 IEC Compliance

All models, DHAA-2270, DHAA-2405 and DHAA-2540 comply with IEC 950.

5.14.4 German Safety Mark

All models, DHAA-2270, DHAA-2405 and DHAA-2540 were approved by TUV on Test Requirement: EN 60 950:1988/A1:1990/A2:1991, but GS mark has not been obtained.

5.14.5 Flammability

The printed circuit boards used in this product is made of material with the UL recognized flammability rating of V-1 or better. The flammability rating is marked or etched on the board. All other parts not considered electrical components are made of material with the UL recognized flammability rating of V-1 or better, except minor mechanical parts.

5.14.6 Safe Handling

The products are conditioned for safe handling in regards to sharp edges and corners.

5.14.7 Environment

The product does not contain any known or suspected carcinogens.

Environmental controls meet or exceed all applicable government regulations in the country of origin. Safe chemical usage and manufacturing control are used to protect the environment. An environmental impact assessment has been done on the manufacturing process used to build the drive, the drive itself, and the disposal of the drive at the end of its life.

Production also meets the requirements of the international treaty on chlorofluorocarbon (CFC) control known as the United Nations Environment Program Montreal Protocol, and as ratified by the member nations. Materials to be controlled include CFC-11, CFC-12, CFC-113, CFC-114, CFC-115, Halon 1211, Halon 1301 and Halon 2402. Although not specified by the Protocol, CFC-112 is also controlled. In addition to the above protocol, IBM controls the following:

- All packaging materials used for the shipment of the product do not use controlled CFCs in the manufacturing process.
- All manufacturing processes for parts or assemblies including printed circuit boards, does not use the controlled CFC materials after December 31, 1993.

5.14.8 Secondary Circuit Protection

The drive uses printed circuit wiring that protects the possibility of sustained combustion due to circuit or component failure. Adequate secondary over-current protection is the responsibility of the using system.

The host system must protect the drive from any electrical short circuit problem. A 10 [A] limit is required for safety purposes.

5.15 Drive Handling

The drives are packed in ESD protective bags at shipment.

After unpacking, the drives need to be handled carefully to prevent any damage by physical shock and ESD.

Handling only by the sides of the disk enclosure and taking a grounded wrist strap are preferred. The printed circuit board, all electronic components and the interface connector should not be touched.

The drives need to be kept on antistatic pad until integrated into the system.

Pressure onto the top cover should not be applied.

6. Electrical Interface Specifications

6.1 Cabling

The maximum cable length from the host system to the HDD plus circuit pattern length in the host system shall not exceed 18 inches.

6.2 Interface Connector

The AT signal connector is designed to mate with Dupont part number 69764-044 or equivalent. Figure 5-1 on page 5-4 and Figure 6-1 show the connector location and physical pin location.

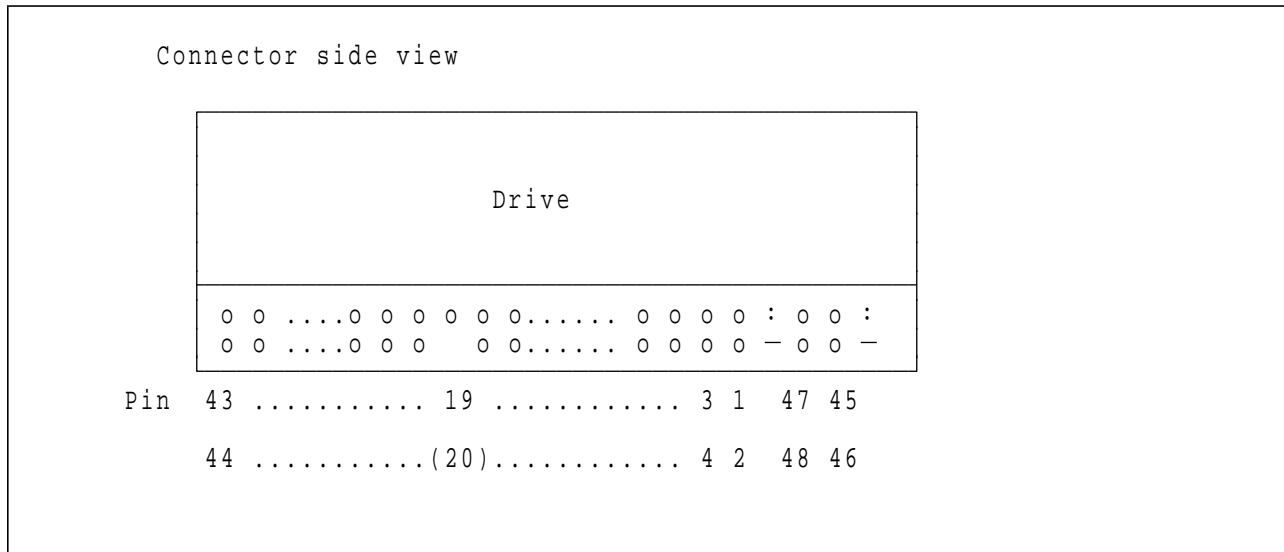

Figure 6-1. 44 pin AT Connector

Note 1 : Pin position 20 is left blank for secure connector insertion.

Note 2 : Pin position 47 through 50 are used for drive address setting. (Refer to Figure 5-2 on page 5-6 for address setting.)

6.3 Signal Definition

The pin assignments of interface signals are as follows:

PIN	SIGNAL	I/O	Type	PIN	SIGNAL	I/O	Type
01	-HRESET	I	TTL	02	GND		
03	HD07	I/O	3-state	04	HD08	I/O	3-state
05	HD06	I/O	3-state	06	HD09	I/O	3-state
07	HD05	I/O	3-state	08	HD10	I/O	3-state
09	HD04	I/O	3-state	10	HD11	I/O	3-state
11	HD03	I/O	3-state	12	HD12	I/O	3-state
13	HD02	I/O	3-state	14	HD13	I/O	3-state
15	HD01	I/O	3-state	16	HD14	I/O	3-state
17	HD00	I/O	3-state	18	HD15	I/O	3-state
19	GND			(20)	Key		
21	DMARQ	0	3-state	22	GND		
23	-HIOW	I	TTL	24	GND		
25	-HIOR	I	TTL	26	GND		
27	IORDY	0	OD	28	CSEL	I	TTL
29	-DMACK	I	TTL	30	GND		
31	HIRQ	0	3-state	32	-HIOCS16	0	OD
33	HA01	I	TTL	34	-PDIAG	I/O	OD
35	HA00	I	TTL	36	HA02	I	TTL
37	-HCS0	I	TTL	38	-HCS1	I	TTL
39	-DASP	I/O	OD	40	GND		
41	+5V LOGIC	PWR		42	+5V MOTOR	PWR	
43	GND			44	(Resv)		

Figure 6-2. Table of signals

Note:

- "O" designates an output from the Drive.
- "I" designates an input to the Drive.
- "I/O" designates an input/output common.
- "PWR" designates a power supply to the Drive.
- "OD" designates Open-Drain output.
- "(Resv)" designates reserved pins which must be left unconnected.

- HD00-HD15** 16-bit bi-directional data bus between the host and the HDD. The lower 8 lines, HD00-07, are used for Register and ECC access. All 16 lines, HD00-15, are used for data transfer. These are Three-State lines have a 24 mA current sink capability.
- HA00-HA02** Address used to select the individual register in the HDD.
- HCS0** Chip select signal generated from the Host address bus. When active, one of the Command Block Registers (Data, Error{Features when written}, Sector Count, Sector Number, Cylinder Low, Cylinder High, Drive/Head and Status{Command when written} register) can be selected.
(See Figure 6-9 on page 6-10 .)
- HCS1** Chip select signal generated from the Host address bus. When active, one of the Control Block Registers (Alternate Status{Device Control when written} and Drive Address register) can be selected.
(See Figure 6-9 on page 6-10 .)
- HRESET** This line is used to reset the HDD. It shall be kept at a Low logic state during power up and kept High thereafter for normal operation.
- HIOW** Its rising edge holds data from the host data bus to a register or data register of the HDD.
- HIOR** When low, this signal enables data from a register or data register of the drive onto data bus. The data on the bus shall be latched on the rising edge of -HIOR.
- HIRQ** Interrupt is enabled only when the drive is selected, and the host activates the -IEN bit in the Device Control Reg. Otherwise, this signal is in high impedance state regardless of the state of the IRQ bit. The interrupt is set when the IRQ bit is set by the drive CPU. IRQ is reset to zero by a host read of the status register or a write to the Command Reg. This signal is a 3-State line with 24 mA sink capability.
- IORDY** Indication to host that the drive is ready to complete current I/O cycle. This line is driven low at the falling edge of -HIOR or -HIOW, when HDD needs some additional WAIT cycle(s) to extend PIO cycle. This line can be connected to host IORDY signal in order to insert WAIT state(s) in the host PIO cycle. This is an Open-Drain output with 24 mA sink capability.
IORDY should be referred only when the PIO cycle time is shorter than 240nsec.
- CSEL** This signal is monitored to determine the drive address, Master or Slave, when the jumper on the interface connector is at Position-3. (Refer to Figure 5-2 on page 5-6 for jumper position.)
When CSEL is ground or at a low level, the HDD works as a Master. If CSEL is open or a high level, the HDD works as a Slave.
The signal level of CSEL to one HDD should be different from the signal level to another HDD on the same AT interface cable, to avoid master-master or slave-slave configurations. Signal level of CSEL should be constant while HDD(s) are on the AT interface.
- HIOCS16** Indication to the host that 16-bit wide data register has been addressed and that the drive is prepared to send or receive a 16-bit wide data word. This signal is an Open-Drain output with 24 mA sink capability and an external resistor is needed to pull this line to 5 Volt.
- DASP** This is a time-multiplexed signal which indicates that a drive is active, or that drive 1 is present. This signal is driven by an Open Collector driver and internally pulled-up to 5 Volt through 10Kohm resistor.
During Power-On initialization or after -RESET is negated, -DASP shall be asserted by Drive 1 within 400 msec to indicate that drive 1 is present. Drive 0 shall allow up to 450msec for drive 1 to assert -DASP. If drive 1 is not present, drive 0 may assert -DASP to drive a LED indicator.

-DASP shall be negated following acceptance of the first valid command by drive 1 or after 31 seconds, whichever comes first.

Anytime after negation of -DASP, either drive may assert -DASP to indicate that a drive is active.

Negation of -DASP also indicates that all data in write cache have been written onto the disk.

-PDIAG

This signal shall be asserted by drive 1 to indicate to drive 0 that it has completed diagnostics. This line is pulled-up to 5 Volt in the HDD through a 10Kohm resistor.

Following a Power On Reset, software reset or -HRESET, drive 1 shall negate -PDIAG within 1 msec (to indicate to drive 0 that it is busy). Drive 1 shall then assert -PDIAG within 30 seconds to indicate that it is no longer busy, and is able to provide status. After the assertion of -PDIAG, drive 1 may be unable to accept commands until it has finished its reset procedure and is ready (DRDY=1).

Following the receipt of a valid Execute Drive Diagnostics command, drive 1 shall negate -PDIAG within 1 msec to indicate to drive 0 that it is busy and has not yet passed its drive diagnostics. If drive 1 is present then drive 0 shall wait for up to 5 seconds from the receipt of a valid Execute Drive Diagnostics command for drive 1 to assert -PDIAG. Drive 1 should clear BSY before asserting -PDIAG, as -PDIAG is use to indicate that drive 1 has passed its diagnostics and is ready to post status.

If -DASP was not asserted by drive 1 during reset initialization, drive 0 shall post its own status immediately after it completes diagnostics, and clear the drive 1 Status register to 00h. Drive 0 may be unable to accept commands until it has finished its reset procedure and is ready (DRDY=1).

KEY

Pin position 20 has no connection pin. It is recommended to key or blank the respective position of the cable connector in order to avoid wrong insertion by mistake.

5V Power

There are two input pins for +5V power supply, "+5V LOGIC" and "+5V MOTOR". "+5V LOGIC" is connected to the internal logic circuits and "+5V MOTOR" is connected to the spindle motor and motor driver.

It is possible to turn on and off "+5V LOGIC" by an external switch circuit to reduce power consumption to the least possible. In this mode, a voltage drop out due to the motor spin up current can be reduced by connecting "+5V MOTOR" line into the system power source directly.

If the above power management is used, all signal lines that will be electrically active in the host system while the HDD is disconnected from power line shall be isolated by Three-State line drivers. Internal leakage through ESD protection circuit may pull down LPUL (Least Positive Up Level) of logic signal below the spec.

Use both lines in parallel, for regular HDD applications.

-DMACK

This signal shall be used by the host in response to DMARQ to either acknowledge that data has been accepted, or that data is available.

DMARQ

This signal, used for DMA data transfers between host and drive, shall be asserted by the drive when it is ready to transfer data to or from the host. The direction of data transfer is controlled by -HIOR and -HIOW. This signal is used on a handshake manner with -DMACK. This signal is a 3-state line with 24mA sink capability and internally pulled-down to GND through 10KOhm resistor.

6.4 Interface Logic Signal Levels

The interface logic signal have the following electrical specifications:

Inputs :	Input High Voltage	2.0 V min./ Vcc+0.7 V max.
	Input Low Voltage	-0.5 V min./ 0.8 V max.
Outputs :	Output High Voltage	2.4 V min.
	Output Low Voltage	0.5 V max.
Current :	Driver Sink Current	24 mA min.
	Driver Source Current	-400 uA min.

Figure 6-3. Interface Logic Signal Levels

6.5 Reset timings

HDD reset timing.

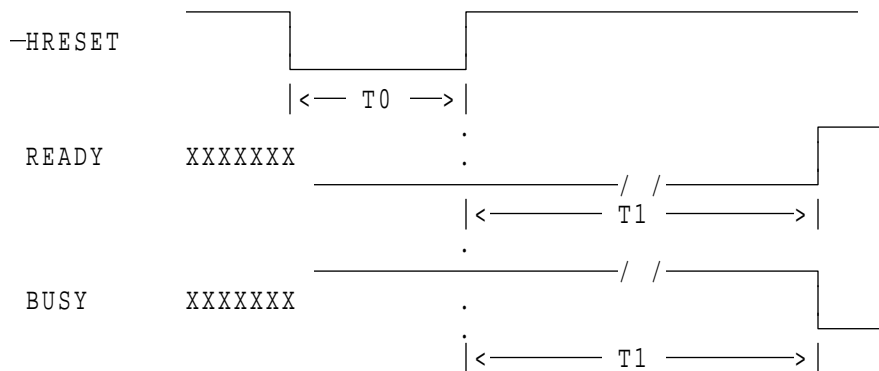

	PARAMETER DESCRIPTION	Min (usec)	Typ (sec)	Max (sec)
T0	-HRESET low width	25	—	—
T1	-HRESET high to READY/Not BUSY	—	2.7	7.5

Figure 6-4. System Reset timing

6.6 PIO Timings

Timings of PIO cycle meet the ATA description for mode 3 PIO timing.

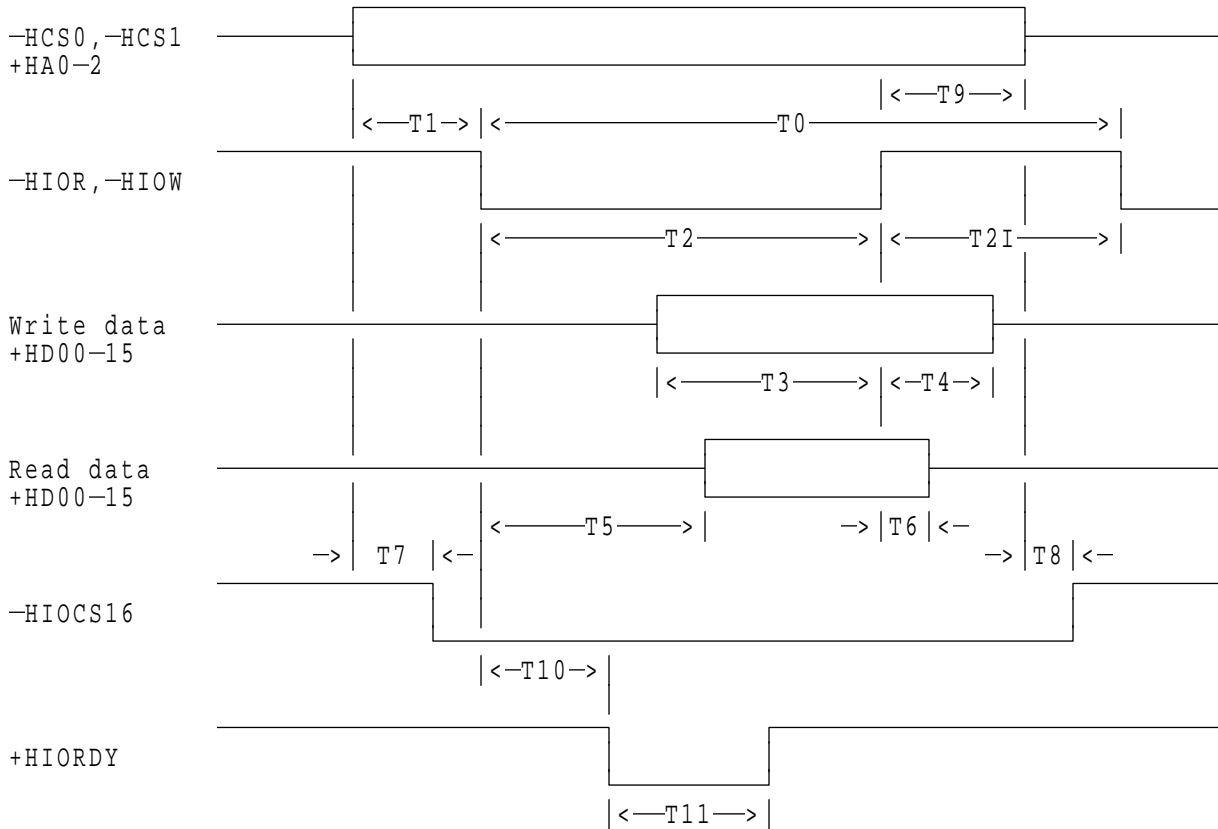

Figure 6-5. PIO cycle timings

In Figure 6-5, the signals should meet the maximum and minimum timings shown in the Figure 6-6.

	PARAMETER DESCRIPTION	MIN (nsec)	MAX (nsec)	Note
T0	Cycle time	180	—	Note
T1	-HCS0-1, +HA00-02 valid to -HIOR, -HIOW active	30	—	
T2	-HIOR, -HIOW pulse width	80	—	
T2I	-HIOR, -HIOW recovery	70	—	
T3	+HD00-15 setup to -HIOW high	30	—	
T4	-HIOW high to +HD00-15 hold	10	—	
T5	-HIOR low to +HD00-15 valid	—	60	
T6	-HIOR high to +HD00-15 hold	5	—	
T7	-HCS0-1, +HA00-02 valid to -HIOCS16 assertion	—	30	
T8	-HCS0-1, +HA00-02 invalid to -HIOCS16 negation	—	30	
T9	-HIOR, -HIOW high to -HCS0-1, +HA00-02 hold	10	—	
T10	-HIOR, -HIOW low to +HIORDY low	—	35	
T11	+HIORDY pulse width	—	100	

Figure 6-6. Interface Timing Limits

Note:

- In case T0 is shorter than 240 ns, system should refer to IORDY signal.
- In case '014E'h is indicated in word 67 of Identify Drive Information, the minimum PIO cycle time (T0) should be limited to 334nsec only for Read Multiple and Write Multiple commands regardless of flow control.

6.6.1 DMA timings (Single Word)

The Single Word DMA timing meets Mode 2 of the ATA description.

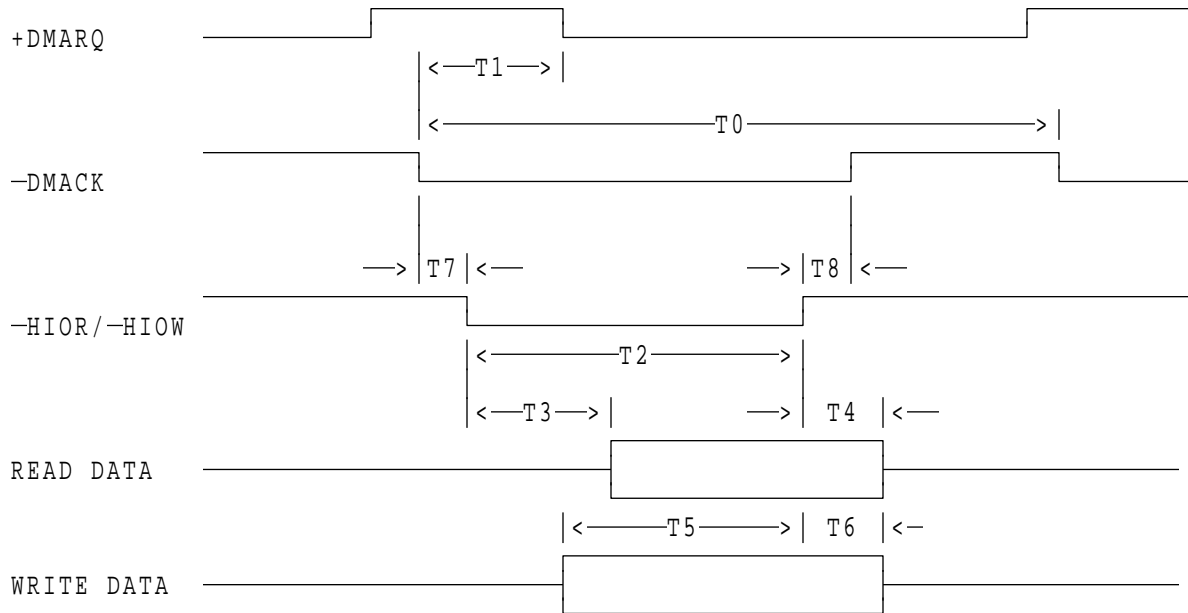

	PARAMETER DESCRIPTION	MIN (nsec)	MAX (nsec)	Note
T0	Cycle time	240	—	
T1	-DMACK active to +DMARQ inactive	—	80	
T2	-HIOR, -HIOW pulse width	120	—	
T3	-HIOR data access	—	60	
T4	-HIOR data hold	5	—	
T5	-HIOW data setup	35	—	
T6	-HIOW data hold	20	—	
T7	-DMACK to -HIOR/-HIOW setup	0	—	
T8	-HIOR/-HIOW to -DMACK hold	0	—	

Figure 6-7. DMA (Single Word) cycle timings

6.6.2 DMA timings (Multiword)

The Multiword DMA timing meets Mode 1.

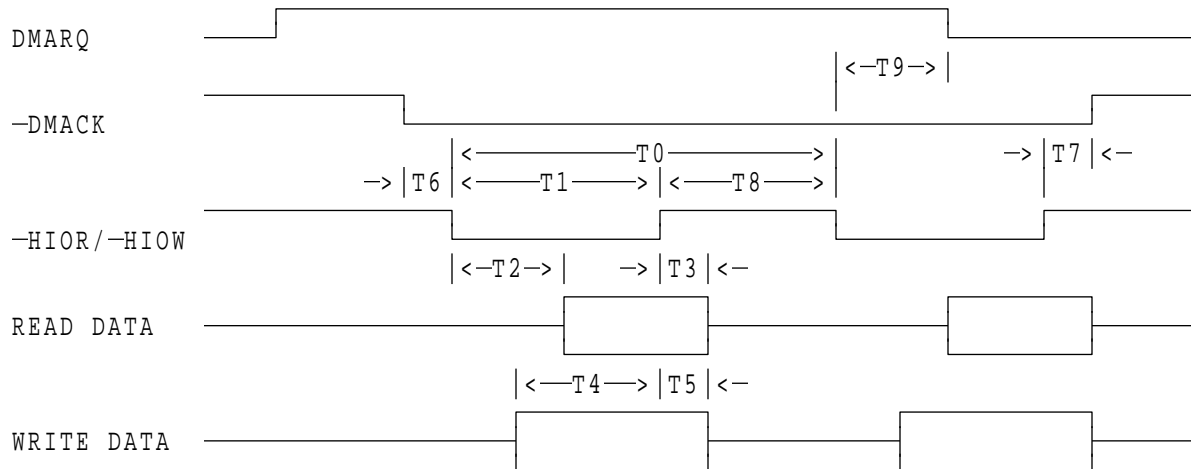

	PARAMETER DESCRIPTION	MIN (nsec)	MAX (nsec)	Note
T0	Cycle time	240	—	
T1	-HIOR, -HIOW pulse width	80	—	
T2	-HIOR data access	—	60	
T3	-HIOR data hold	5	—	
T4	-HIOW data setup	30	—	
T5	-HIOW data hold	15	—	
T6	-DMACK to -HIOR/-HIOW setup	0	—	
T7	-HIOR/-HIOW to -DMACK hold	5	—	
T8	-HIOR/-HIOW negated pulse width	50	—	
T9	-HIOR/-HIOW to +DMARQ delay	—	40	

Figure 6-8. DMA (Multiword) cycle timings

6.7 Addressing of HDD Registers

The host addresses the drive through a set of registers called the Task File. These registers are mapped into the host's I/O space. Two chip select lines (-HCS0 and -HCS1) and three address lines (HA00-02) are used to select one of these registers, while a -HIOR or -HIOW is provided at the specified time.

The -HCS0 is used to address Command Block registers, while the -HCS1 is used to address Control Block registers.

The following table shows the standard I/O address range for IBM PC-AT machines.

Addr.	-HCS0	-HCS1	HA02	HA01	HA00	-HIOR = 0 (Read)	-HIOW = 0 (Write)
Command Block Registers							
1F0	0	1	0	0	0	Data Reg.	Data Reg.
1F1	0	1	0	0	1	Error Reg.	Features Reg.
1F2	0	1	0	1	0	Sector count Reg.	Sector count Reg.
1F3	0	1	0	1	1	Sector number Reg.	Sector number Reg.
1F4	0	1	1	0	0	Cylinder low Reg.	Cylinder low Reg.
1F5	0	1	1	0	1	Cylinder high Reg.	Cylinder high Reg.
1F6	0	1	1	1	0	Drive/Head Reg.	Drive/Head Reg.
1F7	0	1	1	1	1	Status Reg.	Command Reg.
Control Block Registers							
3F6	1	0	1	1	0	Alt. Status Reg.	Device control Reg
3F7	1	0	1	1	1	Drive address Reg.	—

Figure 6-9. Task File

Note: "Addr." field is shown just as an example.



S66G-8101-02